

**Copeland™**  
brand products

# Application Guidelines

## Semi-Hermetic Compressors

### Discus, K, L & S-Series



**EMERSON™**  
Climate Technologies

<b>1</b>	<b>Safety instructions .....</b>	<b>1</b>
1.1	Icon explanation .....	1
1.2	Safety statements .....	1
1.3	General instructions .....	2
<b>2</b>	<b>Product description .....</b>	<b>3</b>
2.1	Common information about Copeland™ semi-hermetic compressors .....	3
2.2	About these guidelines .....	3
2.3	Nomenclature .....	3
2.3.1	<i>Air- or water-cooled compressors</i> .....	3
2.3.2	<i>Suction gas-cooled compressors</i> .....	4
2.4	Nameplate information .....	5
2.4.1	<i>DWM Copeland designation (old models)</i> .....	5
2.4.2	<i>Copeland brand designation (present models)</i> .....	6
2.5	Application range .....	6
2.5.1	<i>Qualified refrigerants and oils</i> .....	6
2.5.2	<i>Application limits</i> .....	6
2.6	Design features .....	7
2.6.1	<i>Construction</i> .....	7
2.6.2	<i>Compressor cooling</i> .....	8
2.6.3	<i>Unloaded start</i> .....	8
2.6.4	<i>Capacity control</i> .....	9
2.6.5	<i>Demand Cooling</i> .....	9
2.6.6	<i>Discharge Temperature Control valve (DTC)</i> .....	9
2.6.7	<i>Running gear lubrication</i> .....	9
2.6.8	<i>Oil pumps – Suction gas-cooled compressors</i> .....	10
2.6.9	<i>Oil pressure</i> .....	10
2.6.10	<i>Oil circulation</i> .....	10
2.6.11	<i>Oil level</i> .....	11
2.6.12	<i>Oil separation &amp; management for booster applications</i> .....	11
2.6.13	<i>R22 Low temperature applications using D2SA–450/X Air &amp; D2SC–550/X Air compressors</i> .....	11
<b>3</b>	<b>Installation .....</b>	<b>12</b>
3.1	Compressor handling .....	12
3.1.1	<i>Delivery</i> .....	12
3.1.2	<i>Transport and storage</i> .....	12
3.1.3	<i>Positioning and securing</i> .....	12
3.1.4	<i>Installation location</i> .....	13
3.1.5	<i>Mounting parts</i> .....	13
3.2	Pressure safety controls .....	14
3.2.1	<i>High-pressure control</i> .....	14

3.2.2	Low-pressure control.....	14
3.2.3	Internal pressure relief valve.....	14
3.2.4	Oil pressure switch.....	14
3.2.5	Maximum allowable pressures.....	15
3.3	Brazing procedure.....	15
3.4	Screens.....	15
<b>4</b>	<b>Electrical connection.....</b>	<b>16</b>
4.1	General recommendations.....	16
4.2	Electrical installation.....	16
4.2.1	Single-phase motors – Code C.....	16
4.2.2	Three-phase motors.....	17
4.2.3	Direct-on-line start motors – Code T.....	17
4.2.4	Star-delta motor (Y/Δ) – Code E.....	17
4.2.5	Part-winding motor (YY/Y) – Code A.....	17
4.3	Wiring diagrams.....	17
4.4	Protection devices.....	17
4.5	Motor protection.....	18
4.5.1	Over-current thermal protection switch for single-phase motors – System A.....	18
4.5.2	Thermistor protection – System W.....	18
4.6	Discharge temperature protection.....	19
4.7	Demand Cooling.....	20
4.8	Oil pressure control.....	20
4.8.1	Oil pressure switch (OPS2).....	20
4.8.2	SENTRONIC Oil pressure control.....	21
4.8.3	Oil pressure switch – ALCO FD 113 ZU (A22 - 057).....	21
4.8.4	Crankcase heaters.....	22
<b>5</b>	<b>Starting up &amp; operation.....</b>	<b>23</b>
5.1	Leak test.....	23
5.2	System evacuation.....	23
5.3	Preliminary checks – Pre-starting.....	23
5.4	Charging procedure.....	23
5.5	Initial start-up.....	24
5.6	Minimum run time.....	24
5.7	Recommended inverter range.....	24
<b>6</b>	<b>Maintenance &amp; repair.....</b>	<b>25</b>
6.1	Exchanging the refrigerant.....	25
6.2	Refrigerant retrofit from HFC to HFO/HFC blends.....	25
6.3	Shut-off valves.....	25
6.4	Compressor replacement.....	25
6.5	Lubrication and oil removal.....	25

6.6	Oil additives .....	26
6.7	Unbrazing system components .....	26
<b>7</b>	<b>Troubleshooting.....</b>	<b>27</b>
7.1	Lubrication problems.....	27
7.2	Oil dilution .....	27
7.3	Refrigerant migration .....	27
7.4	Inadequate suction superheat .....	27
7.5	Acid formation .....	28
7.6	Inadequate compressor cooling.....	28
7.7	High discharge temperatures.....	28
7.8	Motor burnout due to undersized contactors .....	28
7.9	Motor burnout due to by-passed or disconnected protectors .....	28
<b>8</b>	<b>Dismantling &amp; disposal.....</b>	<b>28</b>
<b>Appendix 1 – Compressor connections.....</b>		<b>29</b>
	Standard compressor connections .....	29
	Discus compressor connections .....	35
<b>Appendix 2 - Tightening torques (Nm) .....</b>		<b>38</b>
<b>Disclaimer .....</b>		<b>39</b>



## 1 Safety instructions







Copeland™ semi-hermetic compressors are manufactured according to the latest European safety standards. Particular emphasis has been placed on the user's safety.

These compressors are intended for installation in systems according to the Machinery Directive MD 2006/42/EC. They may be put to service only if they have been installed in these systems according to instructions and conform to the corresponding provisions of legislation. For relevant standards please refer to the Manufacturer's Declaration, available on request.

These instructions should be retained throughout the lifetime of the compressor.

**You are strongly advised to follow these safety instructions.**

### 1.1 Icon explanation

 <p><b>WARNING</b> This icon indicates instructions to avoid personal injury and material damage.</p>	 <p><b>CAUTION</b> This icon indicates instructions to avoid property damage and possible personal injury.</p>
 <p><b>High voltage</b> This icon indicates operations with a danger of electric shock.</p>	 <p><b>IMPORTANT</b> This icon indicates instructions to avoid malfunction of the compressor.</p>
 <p><b>Danger of burning or frostbite</b> This icon indicates operations with a danger of burning or frostbite.</p>	<p><b>NOTE</b> This word indicates a recommendation for easier operation.</p>
 <p><b>Explosion hazard</b> This icon indicates operations with a danger of explosion.</p>	

### 1.2 Safety statements

- Refrigerant compressors must be employed only for their intended use.
- Only qualified and authorized HVAC or refrigeration personnel are permitted to install commission and maintain this equipment.
- Electrical connections must be made by qualified electrical personnel.
- All valid standards for connecting electrical and refrigeration equipment must be observed.
- The national legislation and regulations regarding personnel protection must be observed.



**Use personal safety equipment.** Safety goggles, gloves, protective clothing, safety boots and hard hats should be worn where necessary.

## 1.3 General instructions



### WARNING

**System breakdown! Personal injuries!** Never install a system in the field and leave it unattended when it has no charge, a holding charge, or with the service valves closed without electrically locking out the system.

**System breakdown! Personal injuries!** Only approved refrigerants and refrigeration oils must be used.



### WARNING

**High shell temperature! Burning!** Do not touch the compressor until it has cooled down. Ensure that other materials in the area of the compressor do not get in touch with it. Lock and mark accessible sections.



### CAUTION

**Overheating! Bearing damage!** Do not operate compressors without refrigerant charge or without being connected to the system.



### IMPORTANT

**Transit damage! Compressor malfunction!** Use original packaging. Avoid collisions and tilting.

## 2 Product description

### 2.1 Common information about Copeland™ semi-hermetic compressors

This manual covers all Copeland semi-hermetic compressors. The semi-hermetic reciprocating compressor family consists of different ranges:

- The K-Series and L-Series from 0.5 hp to 4 hp are available as air-cooled or water-cooled versions and use reed valve technology.
- The S-Series includes models 2S, 3S, 4S, 6S and 8S. It is suction gas-cooled and ranges from 5 hp to 70 hp. It uses reed valve technology and offers cost-effective solutions.
- The Discus™ series includes models 2D, 3D, 4D, 6D and 8D and ranges from 4 hp to 60 hp. Its optimized Discus™ valve plate design provides the highest energy efficiency.
- Special applications are addressed with a selected range of 2-stage, Booster and tandem compressors.

Copeland compressors are suitable for a wide range of applications either in the form of single compressors, condensing units or as multi-compressor equipment.

The compressor is only one component which must be combined with many others to build a functional and efficient refrigeration system. Therefore **the information in this manual relates to all semi-hermetic compressors with standard equipment and accessories only.**

### 2.2 About these guidelines

These guidelines are intended to enable users to ensure the safe installation, starting, operation and maintenance of semi-hermetic compressors. They are not intended to replace the system expertise available from system manufacturers.

### 2.3 Nomenclature

The leading character “D” traditionally used DWM COPELAND for compressors is no longer in use in the black painted compressors that use the **Copeland™** brand.

The model designation contains the following technical information about the standard and Discus compressors:

#### 2.3.1 Air- or water-cooled compressors

**Copeland brand designation (present models)**

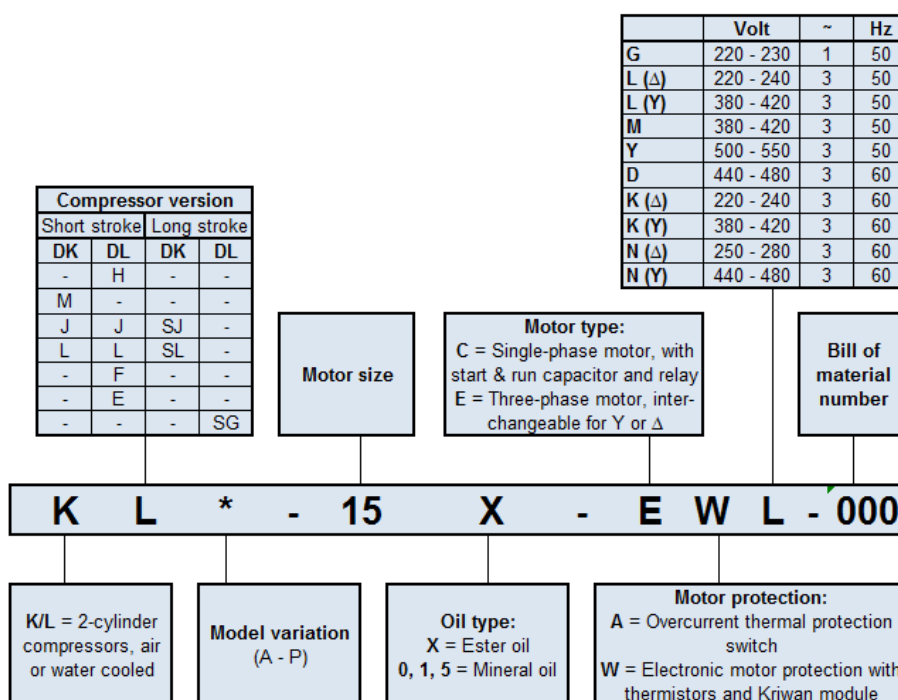



## DWM Copeland designation (old models)

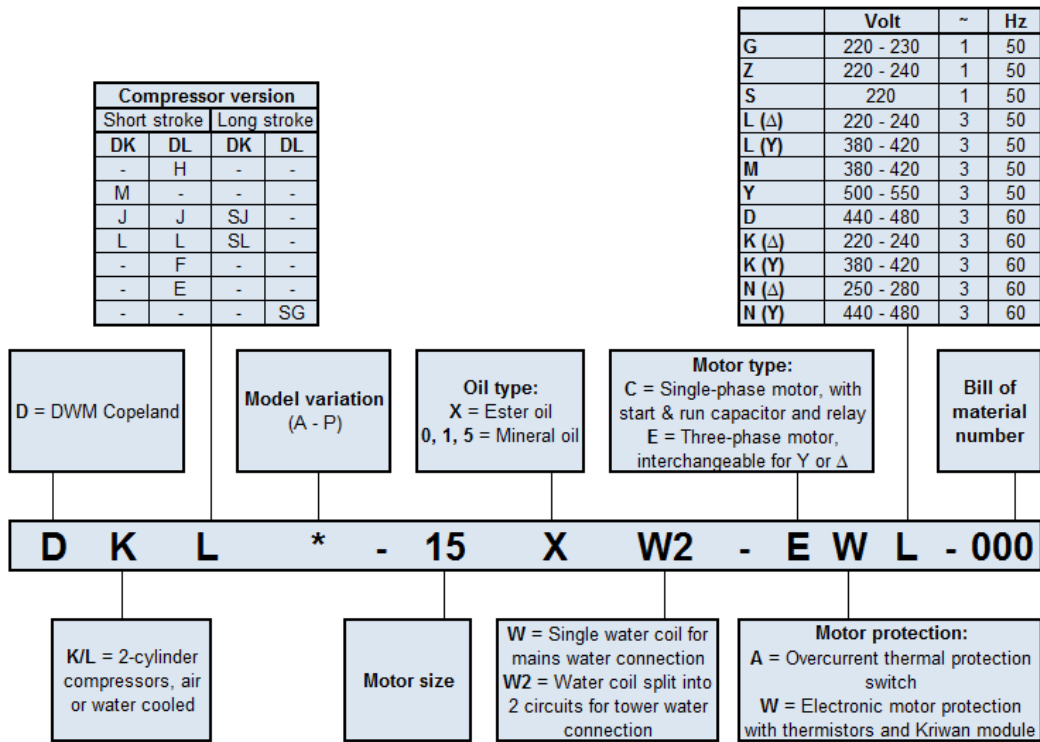

## 2.3.2 Suction gas-cooled compressors

### Copeland brand designation (present models)

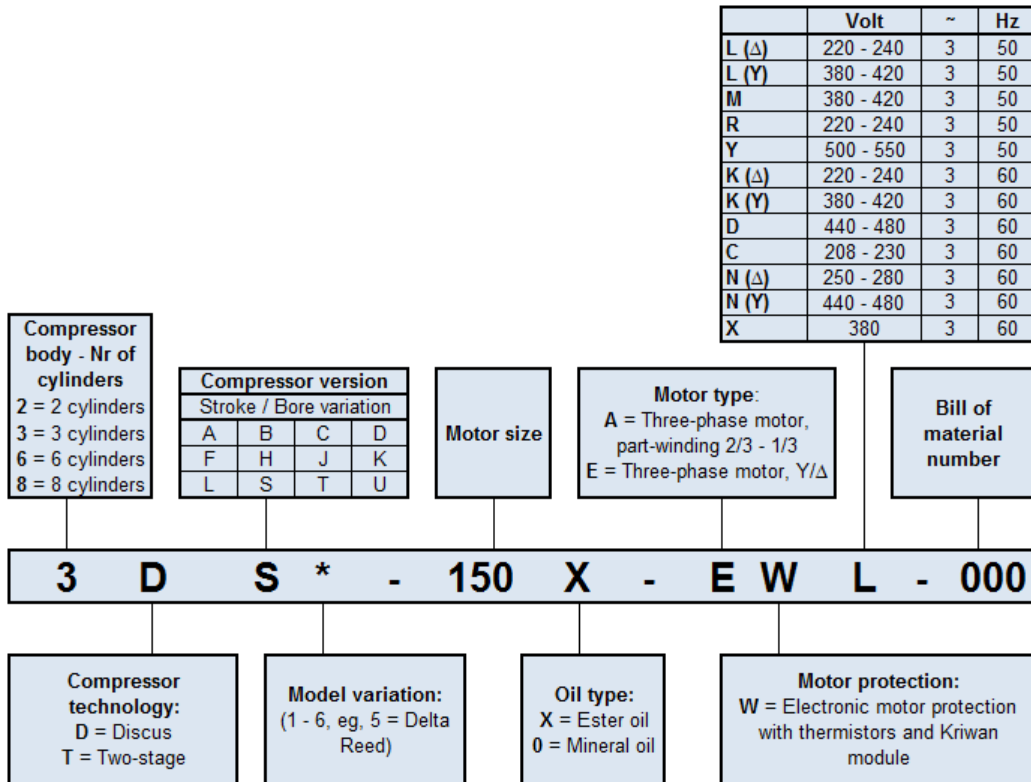

## DWM Copeland designation (old models)

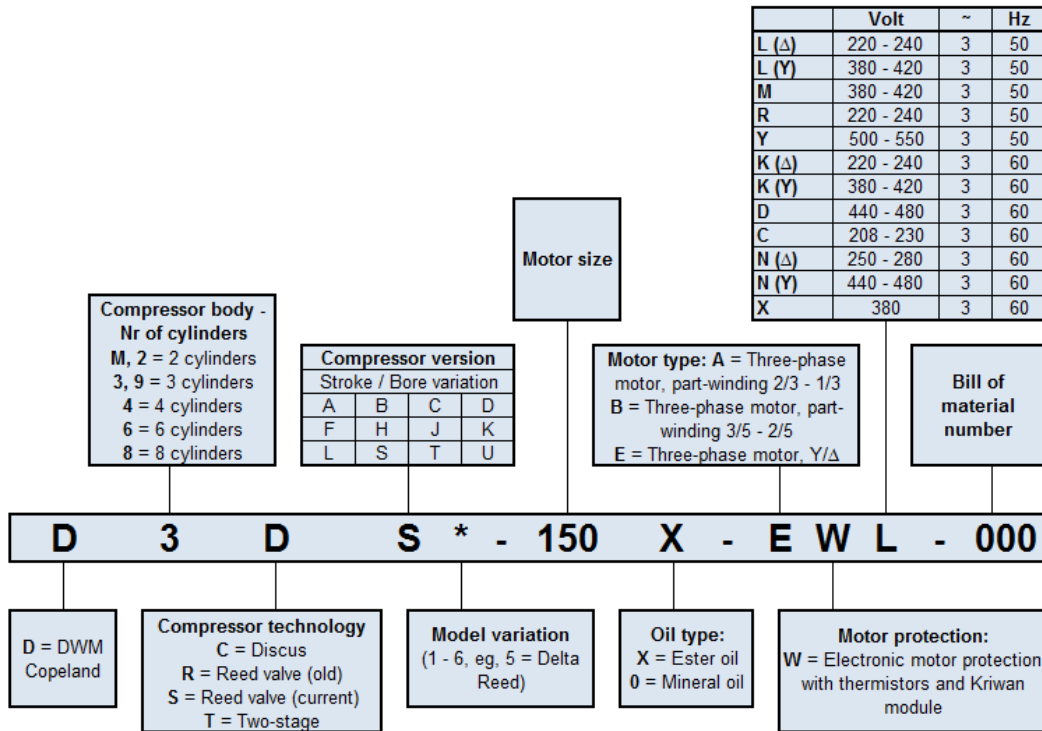

**NOTE:** For more information, please refer to Technical Information D7.4.3 “Copeland™ semi-hermetic compressor model designation”.

### 2.4 Nameplate information

All important information for identification of the compressor is printed on the nameplate.

The type of refrigerant used should be stamped on the nameplate by the installer.

The date of production consists of the year and week of production. In addition the year and month of production are shown as part of the serial number (Jan = A, Feb = B, ... Dec = L).

The mutual nameplate on TWIN compressors only indicates the model and the year of manufacturing. All other details should be taken from the individual compressor nameplates.

#### 2.4.1 DWM Copeland designation (old models)

DK, DL, D2S

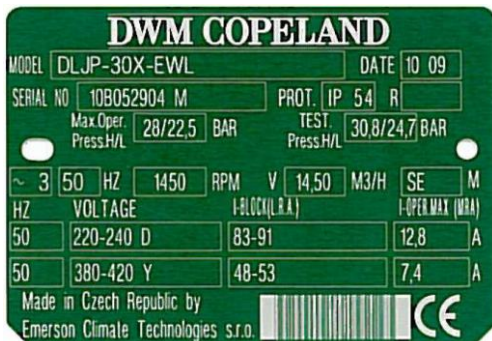

D4S, D4D, D6S/T, D6D, D8S, D8D



D2D, D3D, D3S

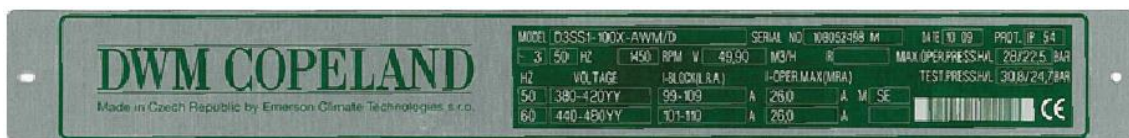

## 2.4.2 Copeland brand designation (present models)

K, L

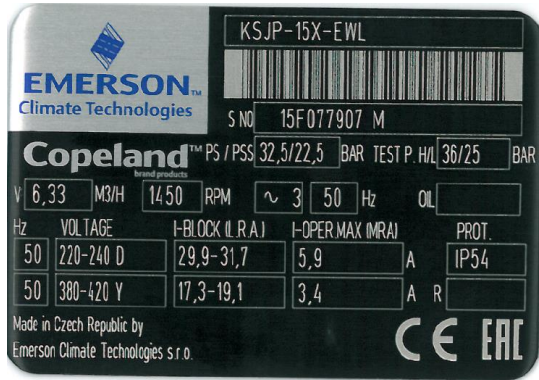

6T, 8D

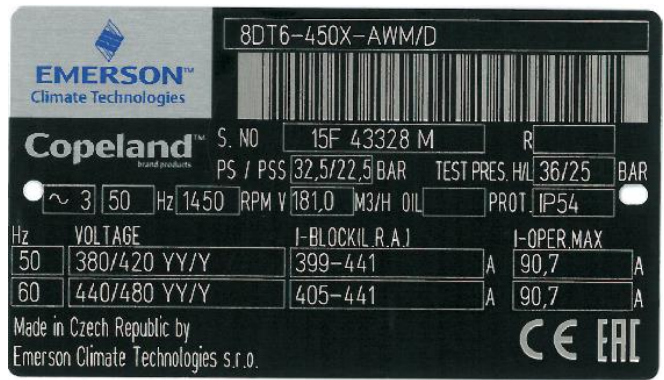

2D, 3D

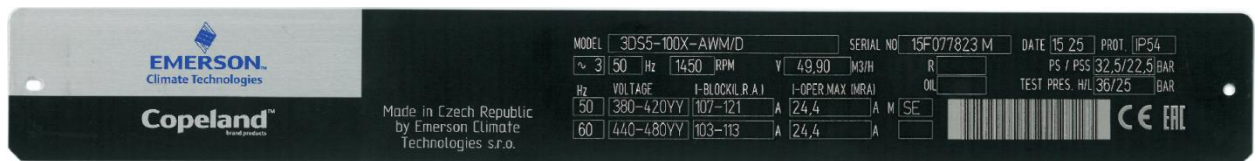

## 2.5 Application range

### 2.5.1 Qualified refrigerants and oils

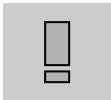

#### IMPORTANT

It is essential that the glide of refrigerant blends (primarily R407C) is carefully considered when adjusting pressure and superheat controls.

Oil recharge values can be taken from Copeland™ brand products Select software available at [www.emersonclimate.eu](http://www.emersonclimate.eu).

<b>Qualified refrigerants</b>	R134a, R404A, R407A*, R407C, R407F*, R448A*, R449A*, R450A, R507, R22	R22
<b>Copeland brand products standard oils</b>	Emkarate RL 32 3MAF	Suniso 3 GS
<b>Servicing oils</b>	Emkarate RL 32 3MAF Mobil EAL Arctic 22 CC	Shell 22-12 Suniso 3 GS Fuchs Reniso KM 32 Capella WF 32

\* Only valid for compressors 2D, 3D and 8D

Table 1: Qualified refrigerants and oils

### 2.5.2 Application limits

For application envelopes please refer to Copeland brand products Select software.

## 2.6 Design features

### 2.6.1 Construction

#### Standard

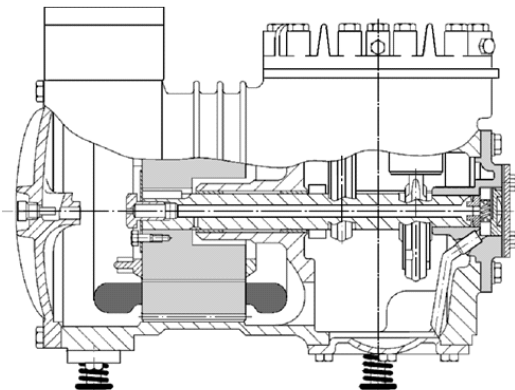

Figure 1

All K-, L- and S-Series compressors are fitted with “Reed” valve plates.

Depending on the number of cylinders, the motor cooling and the kind of application, there are three different compressor families:

- Air- or water-cooled single-stage compressors, models K, L with 2 cylinders and a displacement between 3.97 m<sup>3</sup>/hr and 22.5 m<sup>3</sup>/hr; model LH is air-cooled with a displacement of 26.6 m<sup>3</sup>/hr.
- Refrigerant-cooled single-stage compressors, models D2S, D3S, D4S, D6S and D8S with 2, 3, 4, 6 and 8 cylinders and a displacement between 22.4 m<sup>3</sup>/hr and 210 m<sup>3</sup>/hr.
- Refrigerant-cooled two-stage compressors, model 6T with 6 cylinders and a displacement of 84.7 m<sup>3</sup>/hr.

**NOTE: D2SA-450, D2SA-45X, D2SC-550 & D2SC-55X can be suction gas-cooled or air-cooled compressors depending on the position of the suction service valve.**

In addition, air- or water-cooled compressors have two different kinds of lubrication:

- K & L compressors using mineral oil or semi-synthetic oil and R22 (HCFC) are equipped with a centrifuge lubrication system.
- K & L compressors using ester oil for chlorine-free HFC refrigerants like R404A are equipped with an internal oil pump. The LHA compressor has an external oil pump.

Refrigerant-cooled compressors from D4S upwards are also available as TWIN (Tandem), ie, two compressors of the same type coupled together via a common suction chamber.

Two-stage compressors are used when high pressure ratios are required with acceptable discharge temperatures. On the low-pressure stage (LP, 4 cylinders on 6T) the suction gas is compressed to the inter-stage pressure. The gas enters the motor housing and crankcase via the intermediate pressure mixing line. On the high-pressure stage (HP, 2 cylinders on 6T), the gas is compressed to the condensing pressure.



#### IMPORTANT

Pressures in two-stage compressors are different from those in single-stage compressors, eg, motor compartment and crankcase are under inter-stage pressure.



## Discus

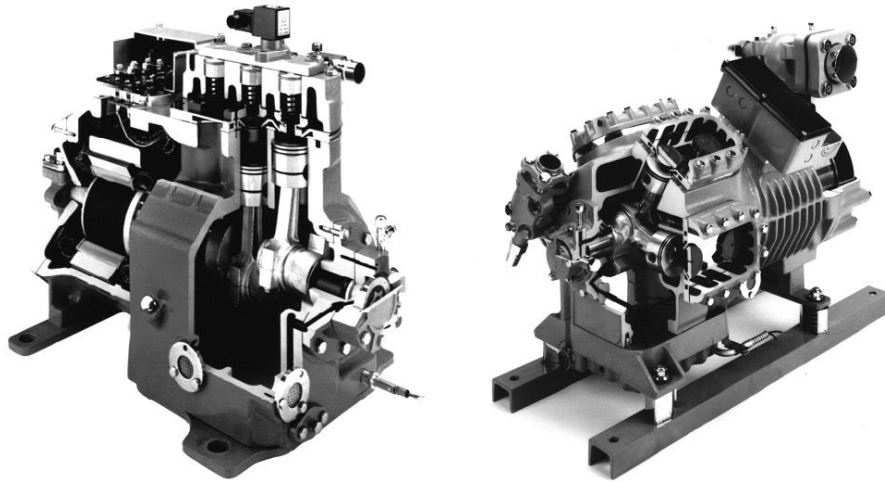

Figure 2

This family consists of refrigerant-cooled single-stage compressors, models 2D, 3D, D4D, D6D and 8D with 2, 3, 4, 6 and 8 cylinders and a displacement between 22.4 m<sup>3</sup>/hr and 181 m<sup>3</sup>/hr.

All compressors are fitted with Discus valve plates which cannot be dismantled. To maintain the high capacity of these compressors the correct valve-plate-to-body gasket must always be selected in case of exchange. The gasket thickness is indicated on the gasket tab.

Each cylinder head has a plugged 1/8" - 27 NPTF tapped hole for connecting high-pressure switches. These high-pressure switches must be calibrated and tested before putting the compressor into service. They must stop the compressor if the allowable pressure is exceeded.

The complete cylinder head is under discharge pressure.

### 2.6.2 Compressor cooling

Compressor motors must always be cooled, and cylinder head cooling may also be needed at certain operating conditions.

K and L compressor motors can utilize air or water cooling. For air cooling, the airflow should be at least 18.5 m<sup>3</sup>/hr. Note that the airflow also cools the cylinder heads. This airflow can come from the fan of an air-cooled condenser or from a separate fan. Some high pressure ratio conditions may require additional head cooling.

For water cooling, the water is led through a water coil wound round the motor section. Usually the water coil is connected before the water-cooled condenser. With mains water, a single coil "W" is used, and with cooling-tower connection a split coil "W2" is used. To improve heat transmission, the water coil is embedded into thermocement on motors >0.75 HP but smaller than 4 HP. If cylinder head cooling is also required, an additional fan must be installed with water-cooled compressors.

All compressors starting with 2\* until 8\* are suction gas-cooled. With suction gas-cooled compressors, the motor is cooled by refrigerant gas that is led over the motor. An additional fan may be required depending upon the operating condition (see Copeland brand products Select software).

**NOTE:** For additional fan cooler mounting instructions, please refer to Technical Information D7.11.1 "Semi-hermetic compressors – Additional fans".

**NOTE:** R22 is no longer allowed for new refrigeration systems in Europe.

### 2.6.3 Unloaded start

With direct starting the motor of a compressor is switched directly into the mains by means of a switch. The resulting breakaway starting current amounts to multiple times the rated motor current (operating maximum) without consideration being given to transient phenomena.

In the case of high-powered motors the breakaway starting currents become so large that they lead to disruptive voltage dips in the mains. The compressors that are subject to current limitation must therefore by all means be equipped with starting load reduction to guarantee

perfect starting even when the voltages amount to less than approximately 85% of the voltage on the nameplate.

Unloaded start is not available for Copeland brand 2-stage compressors and K/L.

**NOTE: For more information please refer to Technical Information D7.10.2 “Starting methods and unloaded start for semi-hermetic compressors”.**

### 2.6.4 Capacity control

For 3, 4, 6 and 8 cylinder compressors a mechanical capacity control is available. Be aware that unloaded operation changes the application range of the compressor.

**NOTE: For more information please refer to Technical Information D7.21.1 “Semi-hermetic compressors capacity control”.**

### 2.6.5 Demand Cooling

“Demand cooling”, as the term implies, means liquid refrigerant injection on demand.

If a low-temperature R22 installation is required, the following compressors can be equipped with a Demand Cooling accessory kit:

2DL* - 400	D4DF* - 1000
2DB* - 500	D4DL* - 1500
3DA* - 500	D4DT* - 2200
3DC* - 750	D6DL* - 2700
3DS* - 1000	D6DT* - 3000

\* The fourth or fifth digit of the model designation must be  $\geq 3$  for D4D & D6D and  $\geq 4$  for 3D.

### 2.6.6 Discharge Temperature Control valve (DTC)

The Discharge Temperature Control valve liquid injection system is a low cost and reliable solution for the D3SC-750/X, D3SS-1000/X, D4SL/T, D6SL/T and D6SU compressors to obtain lower evaporating temperatures within an extended operating envelope.

The afore-mentioned compressors are equipped with a plugged injection port on the side of the compressor wall close to the base of the cylinder block. The injection port can be retro-fitted with the DTC valve. The temperature sensing element with 12” NPT thread fits on the D4SL/T, D6SL/T and D6SU compressor body close to the discharge shut-off valve.

Please note that:

- DTC is needed only in systems with R22 refrigerant.
- The valve can be obtained as an optional extra.
- It is recommended to use an additional fan with the DTC valve for performance values as shown in Copeland brand products Select software.
- The D4SL/T, D6SL/T and D6SU compressors with DTC valve and fan operate with a voltage tolerance of  $\pm 5\%$  over the complete operating envelope.

**NOTE: For more information please refer to Technical Information D7.19.1 “Assembling the DTC valve for semi-hermetic R22 low temperature applications”.**

### 2.6.7 Running gear lubrication

#### Air- or water-cooled compressors

Air- or water-cooled compressors that are filled with mineral oil have an oil centrifuge. The oil supplied is drawn over a magnetic plug in order to separate even the smallest iron particles from the oil.

Air- or water-cooled compressors that are lubricated with ester oil have an integral low-pressure oil pump. These compressors, with pump and ester oil filling, are marked with “P” in compressor nomenclature. An exception is the KSLP-200 which has an oil pump but is filled with mineral oil.

## K & L compressor oil circulation

The oil returning from the evaporator reaches the crankcase via an oil separator chamber behind the suction shut-off valve through a small connecting bore. Due to this connecting bore the crankcase pressure will be decreased slowly when the compressor starts. Thus the foaming of the oil and refrigerant mixture will be reduced.

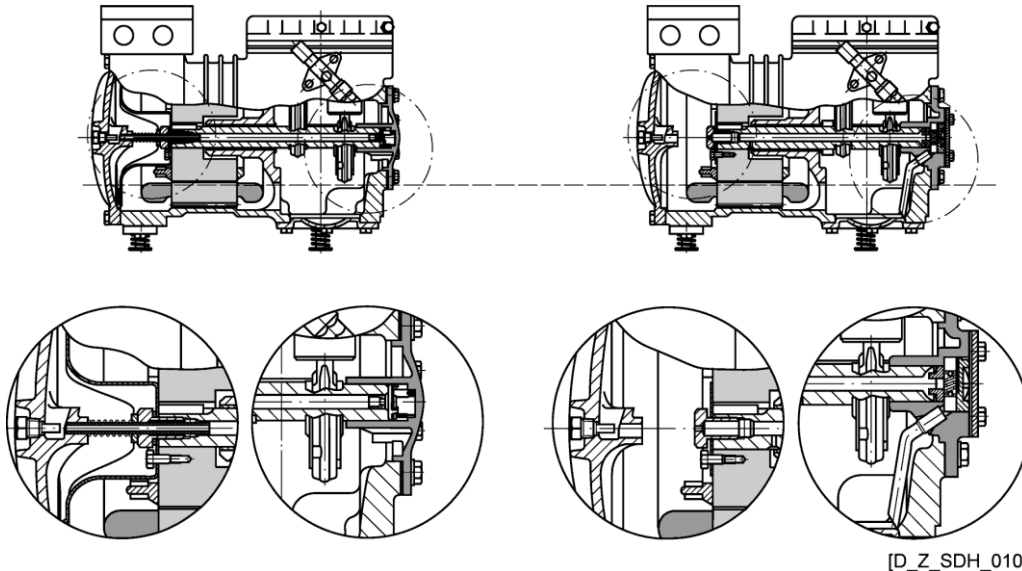

[D\_Z\_SDH\_010]

Figure 3: K & L compressors lubrication

### 2.6.8 Oil pumps – Suction gas-cooled compressors

The oil pumps used for standard and Discus compressors are independent of their rotating direction. They are designed to accommodate fittings for an OPS1, OPS2, SENTRONIC oil safety system or a standard oil pressure switch.

### 2.6.9 Oil pressure

Normal oil pressure is between 1.05 and 4.2 bar higher than crankcase pressure. Net oil pressure can be read by connecting two pressure gauges to the compressor and comparing the readings. One gauge should be connected to the oil pump. The second gauge should be connected to the crankcase (T-fitting instead of plug on the compressor crankcase) or the suction service valve.

During irregular operating conditions, eg, a blockage of the suction filter, the pressure measured at the suction shut-off valve of the compressor may differ widely from that measured at the crankcase therefore pressure drops have to be avoided.

### 2.6.10 Oil circulation

Oil returns with the suction gases through a suction strainer and separates in the motor chamber reaching the crankcase by way of a pressure relief valve in the partition between motor housing and crankcase. This relief valve closes on compressor start-up due to the pressure difference arising between motor side and crankcase, thus slowing down pressure decrease in the crankcase over a certain period of time. It reduces the foaming of the oil/refrigerant mixture that would occur if the pressure decreased rapidly.

The valve does not reopen until the pressure has been equalized by means of a crankcase ventilating valve. This second valve connects the crankcase and suction side cylinder head. It reduces the pressure difference by means of a very small bore in the plate of the valve so slowly that oil foams less and only limited oil/refrigerant foam is transferred to the oil pump.

## 2.6.11 Oil level

All compressors are delivered with sufficient oil for normal operation (see oil quantities in Select). The optimum oil level should be checked by operating the compressor until the system is stable and then comparing the sight glass reading with the appropriate diagram below. The level can also be checked within 10 sec. of compressor shut-down. For 4- to 8-cylinder compressors a higher oil level may be accepted when an oil regulator is in use because the oil separator will reduce excessive oil circulation.

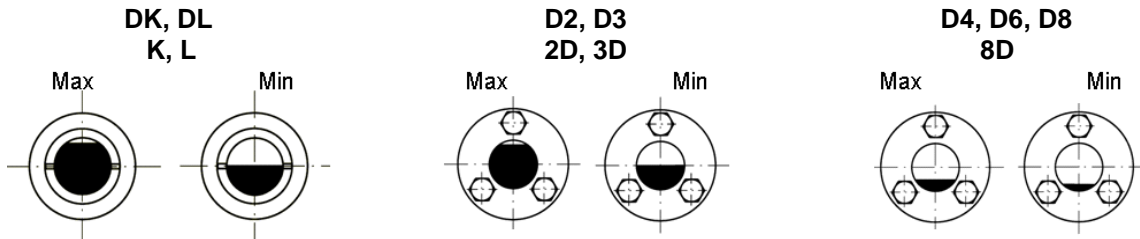

Figure 4

## 2.6.12 Oil separation & management for booster applications

In direct-stage refrigeration systems, oil carried over from each compressor may accumulate in one of the compressors in series resulting in a lack of lubrication for the others. To ensure each compressor has the correct amount of oil returned, Emerson Climate Technologies recommends the use of a highly efficient cyclone or coalescent type oil separator with an oil management system. The oil separator shall be installed in the discharge line of the high stage compressor. It will separate the oil from the discharge gas and pass it to an oil reservoir. The oil will then pass from the oil reservoir through the oil management system to each individual compressor ensuring full lubrication and extended compressor life and reliability.

## 2.6.13 R22 Low temperature applications using D2SA-450/X Air & D2SC-550/X Air compressors

R22 low temperature applications require suction superheat limitations for both the D2S and D3S compressors (refer to the operating envelope in Copeland brand products Select software for details). With the D2S range this is achieved by repositioning the suction valve, moving it from the motor cover end to the compressor body. This changes the compressor from a suction gas-cooled model to an air-cooled model. We now have the “D2SA-45X Air”, “D2SA-450 Air”, “D2SC-55X Air” and “D2SC-550 Air” air-cooled compressors. The D2SK-65X and D2SK-650 models cannot be run at low temperatures using R22. The smallest D3SC model should be used for these applications (almost the same capacity at low temperature as the D2SK).



## 3 Installation



### WARNING

**High pressure! Injury to skin and eyes possible!** Be careful when opening connections on a pressurized item.

### 3.1 Compressor handling

#### 3.1.1 Delivery

Please check whether the delivery is correct and complete. Deficiencies should be reported immediately in writing.

Standard delivery:

- Suction and discharge shut-off valves
- Oil charge, oil sight glass
- Mounting kit
- Motor protector
- Holding charge up to 2.5 bar(g) (dry air)

#### 3.1.2 Transport and storage



### WARNING

**Risk of collapse! Personal injuries!** Move compressors only with appropriate mechanical or handling equipment according to weight. Keep in the upright position. Stack pallets on top of each other when not exceeding 300 kg. Stacking higher than the recommended maximum can cause accidents. Do not stack single boxes on top of each other. Keep the packaging dry at all times.

Compressors are individually packed and may be delivered on pallets depending on quantity and size. Cooling fans are delivered in separate cartons. Accessories may be mounted or delivered loose. Solenoid valves are never mounted.

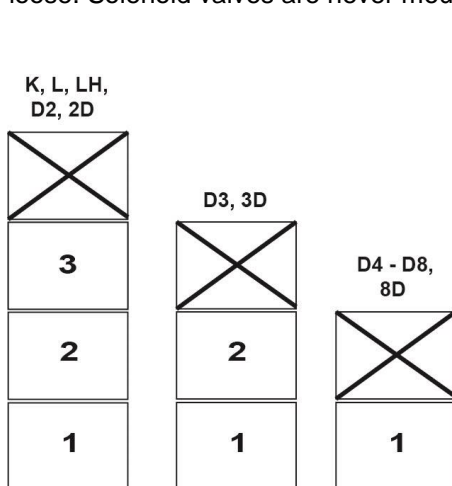

Figure 5: Transport

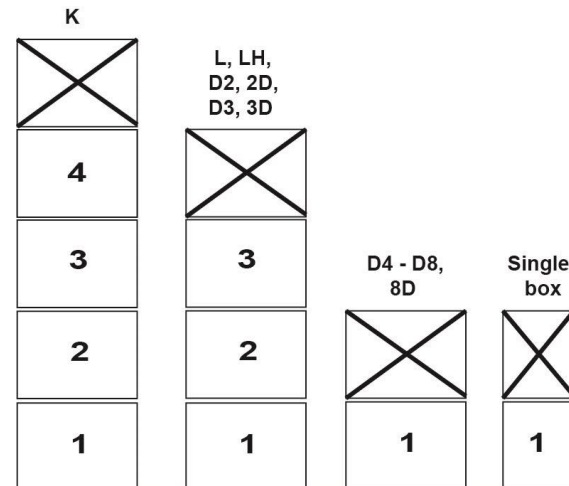

Figure 6: Storage

#### 3.1.3 Positioning and securing



### IMPORTANT

**Handling damage! Compressor malfunction!** Only use the lifting eyes whenever the compressor requires positioning. Using discharge or suction connections for lifting may cause damage or leaks.

If possible, the compressor should be kept vertical during handling.

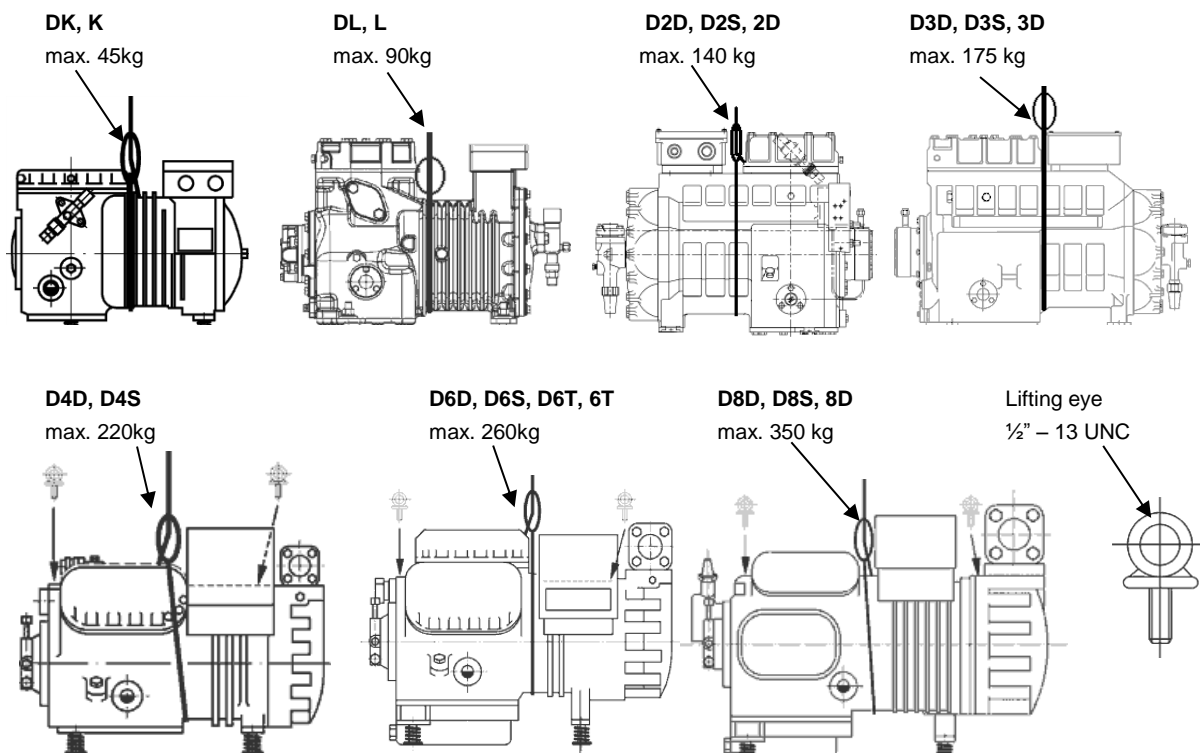

Figure 7

### 3.1.4 Installation location

Ensure the compressors are installed on a solid level base.

### 3.1.5 Mounting parts

To minimize vibration and start/stop impulses flexible mounting should be used. For this purpose coloured springs are delivered with each compressor. These springs should be mounted according to the prescriptions given in Technical Information D7.11.2 “Mounting parts for semi-hermetic compressors”.

A compressor may be rigidly mounted, ie, without springs. In this case more shock and vibration loading will be transmitted to the frame.

If the installation requires a very high level of vibration absorption, additional vibration absorbers (available on the market) can be fitted between the rails and the foundation.

To ensure proper lubrication of moving parts, the compressor should be installed horizontally on both axes. TWIN compressors are fitted to mounting rails using rubber pads.

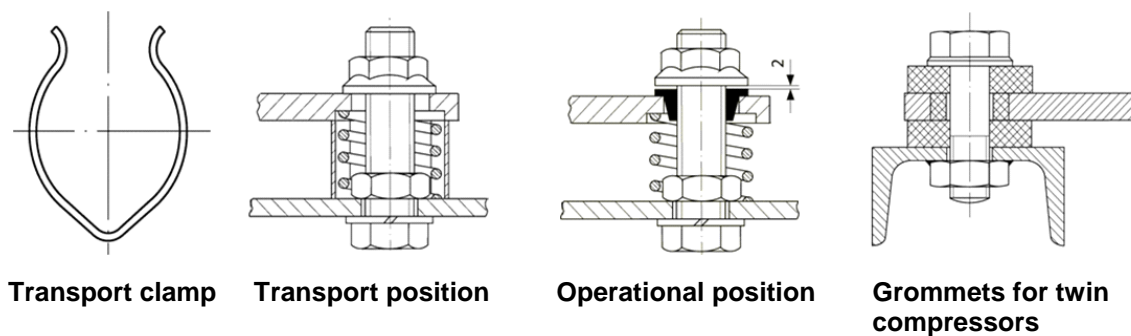

Figure 8

## 3.2 Pressure safety controls

### 3.2.1 High-pressure control

A high-pressure control with a maximum cut-out setting of 28.8 bar(g) is required.

The high-pressure cut-out should have a manual reset feature for the highest level of system protection.

### 3.2.2 Low-pressure control

The normal minimum is 0.1 bar(g) for R404A.

The low-pressure cut-out should have a manual reset feature for the highest level of system protection.

### 3.2.3 Internal pressure relief valve

Single-stage compressors (50 Hz) with a displacement  $\geq 50\text{m}^3/\text{hr}$  are equipped with an internal pressure relief valve placed between suction chamber and discharge chamber. This valve protects the compressor against bursting if the discharge shut-off valve is accidentally fully closed.

On two-stage compressors this valve is placed between inter-stage and low-pressure side and opens at  $\approx 15$  bar (see **Figure 9**).

**NOTE: The valve will not protect the installation against dangerous system pressures!**

Before operating the compressors the pressure switches and other safety devices must be installed correctly. Maximum allowable pressures must not be exceeded.

For connecting a high-pressure switch there is a tapped hole with plug in 1/8" – 27 NPTF on each cylinder head.

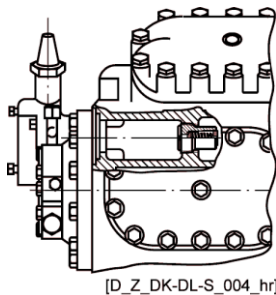

Figure 9

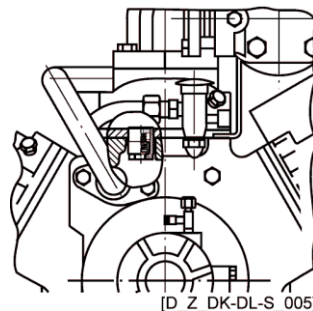

Figure 10

### 3.2.4 Oil pressure switch

The oil pressure switch breaks the control circuit when the pressure difference between the oil pump outlet and the crankcase is too low. The switch must be properly adjusted and tamper proof. If the oil differential pressure drops below the minimum acceptable value the compressor will be stopped after a 120-second delay. After having solved the problem the control has to be reset manually.

**NOTE: Proper oil pressure safety control with an approved switch is a condition of warranty!**

Specifications for electro-mechanical oil pressure switches are as follows:

- Cut-out pressure:  $0.63 \pm 0.14$  bar
- Cut-in pressure:  $0.9 \pm 0.1$  bar
- Time delay:  $120 \pm 15$  sec.

The Alco Control FD-113-ZU mechanical oil pressure switch operates with the above set points.

### 3.2.5 Maximum allowable pressures

The maximum allowable pressures (according to EN 12693) shown on the compressor nameplate are obligatory and must not be exceeded.

- High pressure side (HP): 28.0 bar(g) (up to S/N 14K46143M & 14K031872M)  
32.5 bar(g) (from S/N 14K46144M & 14K031873M onwards)
- Low pressure side (LP): 22.5 bar

**NOTE: The compressor operating range may be restricted for various reasons. Check the application range limitations in Copeland brand products Select software and on [www.emersonclimate.eu](http://www.emersonclimate.eu).**

### 3.3 Brazing procedure

#### IMPORTANT



**Blockage! Compressor breakdown!** Maintain a flow of oxygen-free nitrogen through the system at very low pressure during brazing. Nitrogen displaces the air and prevents the formation of copper oxides in the system. If allowed to form, the copper oxide material can later be swept through the system and block screens such as those protecting capillary tubes, thermal expansion valves, and accumulator oil return holes.

**Contamination or moisture! Bearing failure!** Do not remove the plugs until the compressor is set into the unit. This minimises any entry of contaminants and moisture.

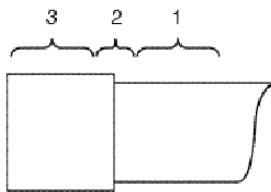

Figure 11: Brazing areas

Figure 11 shows the proper procedure for brazing the suction and discharge shut-off valves.

- The shut-off valves of the compressors can be brazed in approximately the same manner as any copper tube.
  - Recommended brazing materials: any silfos material is recommended, preferably with a minimum of 5% silver. However, 0% silver is acceptable.
  - Be sure tube fitting inner diameter and tube outer diameter are clean prior to assembly.
  - Using a double-tipped torch, apply heat in area 1.
- As the tube approaches brazing temperature, move the torch flame to area 2.
- Heat area 2 until braze temperature is attained, moving the torch up and down and rotating around the tube as necessary to heat the tube evenly. Add braze material to the joint while moving the torch around the joint to flow braze material around the circumference.
- After the braze material flows around the joint, move the torch to heat area 3. This will draw the braze material down into the joint. The time spent heating area 3 should be minimal.
- As with any brazed joint, overheating may be detrimental to the final result.

#### To disconnect:

- Heat joint areas 2 and 3 slowly and uniformly until the braze material softens and the tube can be pulled out of the fitting.

#### To reconnect:

- Recommended brazing materials: Silfos with minimum 5% silver or silver braze used on other compressors. Due to the different thermal properties of steel and copper, brazing procedures may have to be changed from those commonly used.

### 3.4 Screens



#### CAUTION

**Screen blocking! Compressor breakdown!** Use screens with at least 0.6 mm openings.

The use of screens finer than 30 x 30 meshes (0.6 mm openings) anywhere in the system should be avoided with these compressors. Field experience has shown that finer mesh screens used to protect thermal expansion valves, capillary tubes or accumulators can become temporarily or permanently plugged with normal system debris and block the flow of either oil or refrigerant to the compressor. Such blockage can result in compressor failure.

## 4 Electrical connection

### 4.1 General recommendations

The compressor terminal box has a wiring diagram on the inside of its cover. Before connecting the compressor, ensure the supply voltage, the phases and the frequency match the nameplate data.

When the compressor is shipped the motor protector is mounted in the terminal box. The thermistors are factory connected. The power supply and the control circuit must be wired according to the wiring diagram (see wiring diagram on the inside of the terminal box lid).

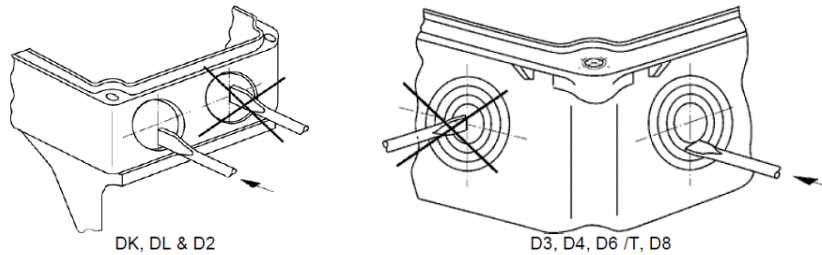

Figure 12: Terminal box preparation for cable gland fitting - Note position of screwdriver!

Position at terminal box	Diameter of hole at terminal box (mm)	Cable bushing metric	Outside diameter (mm)
1	20.6	M20 x 1.5	20
2	32.5	M32 x 1.5	32
3	50.5	M50 x 1.5	50
4	63.5	M63 x 1.5	63

Table 2: Characteristics of the holes for cable bushings

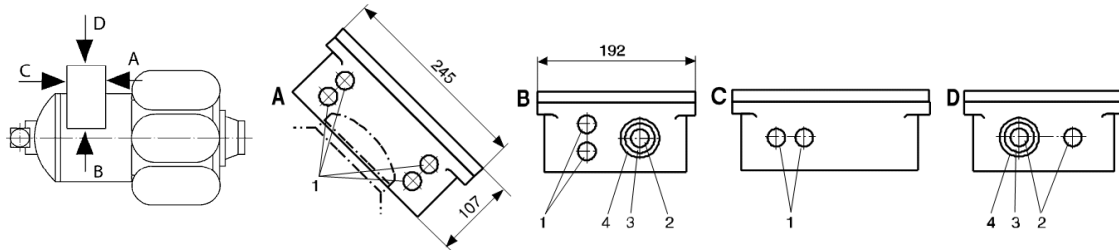

Figure 13: Position of the holes for cable bushings (top view of a 6-cylinder compressor)

The protection class of each terminal box according to IEC 60529 is given in **Table 3** hereunder:

Old models	Present models	Class	Option
DK, DL, D2D, D2S	K, L, 2D	IP54	-
D3D, D3S	3D	IP54	IP56
D4D, D4S		IP54	IP56
D6D, D6S, D6T	6T	IP54	IP56
D8D, D8S	8D	IP54	IP56

Table 3: Protection class of terminal box according to IEC 60529

Cable glands can influence the protection class. Factory-fitted cable glands reduce the protection class to IP41.

### 4.2 Electrical installation

#### 4.2.1 Single-phase motors – Code C

Compressors up to model DKSL-15X are available with single-phase motors. They have one main and one auxiliary winding. A single-phase equipment consisting of a start and run capacitor

and a potential relay, is needed for proper operation. Assembly must be in accordance with the position of the relay shown on the wiring diagram.

### 4.2.2 Three-phase motors

All compressors can be started direct-on-line. The necessary position of bridges for direct-on-line start (depending on type of motor and/or mains voltage) is shown on the principle wiring in section 4.3.1.

### 4.2.3 Direct-on-line start motors – Code T

This motor is only suitable for one voltage and can only be started direct-on-line. The motor winding is internally connected into delta or star and 3 winding ends are connected to the terminals U, V, W in the terminal box.

### 4.2.4 Star-delta motor (Y/Δ) – Code E

This motor is interchangeable for star (Y) or delta (Δ) operation by means of bridges. It is suitable for two voltage ranges, eg, 220V-240V in delta, 380V-420V in star connection. If the supply voltage and the nominal voltage of the motor in Δ-connection are identical, the star connection motor can also be used for starting (remove bridges!).

### 4.2.5 Part-winding motor (YY/Y) – Code A

PWS motors contain two separate windings (2/3 + 1/3) which are internally connected in star and operated in parallel. You cannot change the voltage by changing the electrical connections. The motor is only suitable for one voltage range.

The first part winding, the 2/3 winding on terminals 1-2-3 can be used for part winding start (remove the bridges). After a time delay of  $1 \pm 0.1$  seconds the second part winding, the 1/3 winding on terminals 7-8-9 must be brought on line.

## 4.3 Wiring diagrams

For wiring diagrams of recommended power and control circuit, please refer to our website at [www.emersonclimate.eu](http://www.emersonclimate.eu).

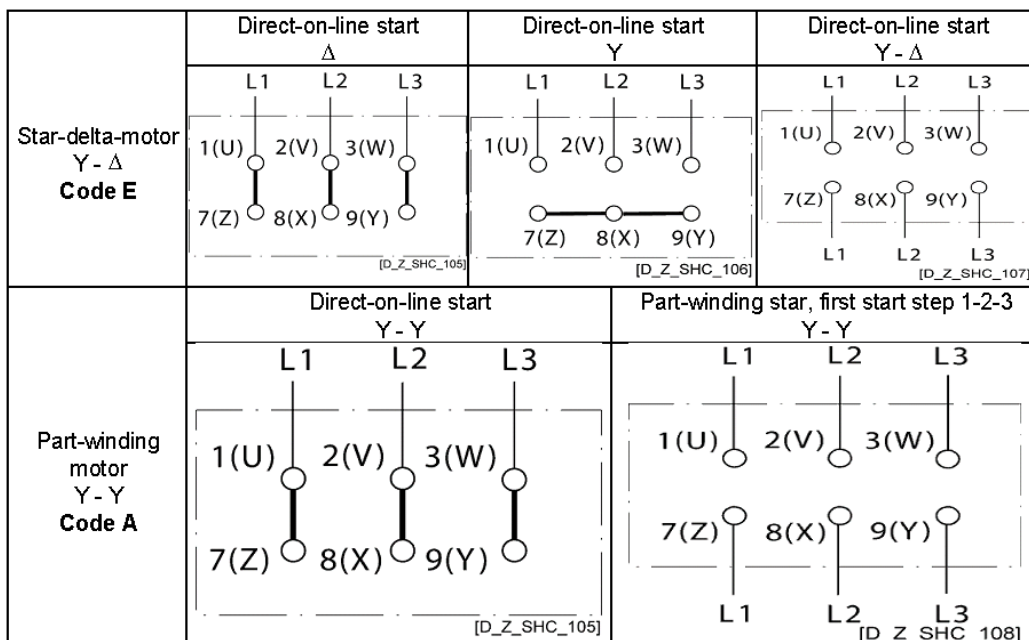

Figure 14: Jumper position compressor motor

## 4.4 Protection devices

Independently from the internal motor protection, fuses must be installed before the compressor. The selection of fuses has to be carried out according to VDE 0635, DIN 57635, IEC 269-1 or EN 60269-1.



## 4.5 Motor protection

Each compressor has a motor protector. An external overload protection is not necessary.

### 4.5.1 Over-current thermal protection switch for single-phase motors – System A



#### WARNING

**Compressor under voltage! Electrical shock!** When the motor stops due to the over-current thermal protection switch, the compressor is still under voltage!

This bimetal switch is installed in the terminal box. It is heated by the motor current and by the motor bundle of laminations, and combines the function of an over-current tripping device and thermal protection switch. When the switch responds, it interrupts the voltage supply to the motor directly, not the control line. When the motor winding cools off, it switches on again automatically.

### 4.5.2 Thermistor protection – System W

All 3-phase motors with a “W” in the motor code have a thermistor protection device. The temperature-dependent resistance of the thermistor (also PTC-resistance) is used to sense the winding temperature. A chain of three thermistors (on 2 and 3 cylinder compressors) or two chains of three thermistors each (on 4, 6 and 8 cylinder compressors) connected in series are embedded in the motor windings in such a manner that the temperature of the thermistors can follow with little inertia.

An electronic release module is required which switches a control relay, depending on the thermistor resistance. The release module INT69-2 for one thermistor chain or two chains with a 5-minute time delay, INT69TM-2 for two chains, is installed in the terminal box to which the thermistors are connected.

**Caution: The maximum test voltage for thermistors is 3V.**

The total resistance of the thermistor chains on a cold compressor should be  $\leq 1800\Omega$ .

**Internal wiring:** The current compressors use a new generation of thermistor protection (INT69-2 & INT69TM-2) that has the same main features as the previous one (INT69 & INT69TM).

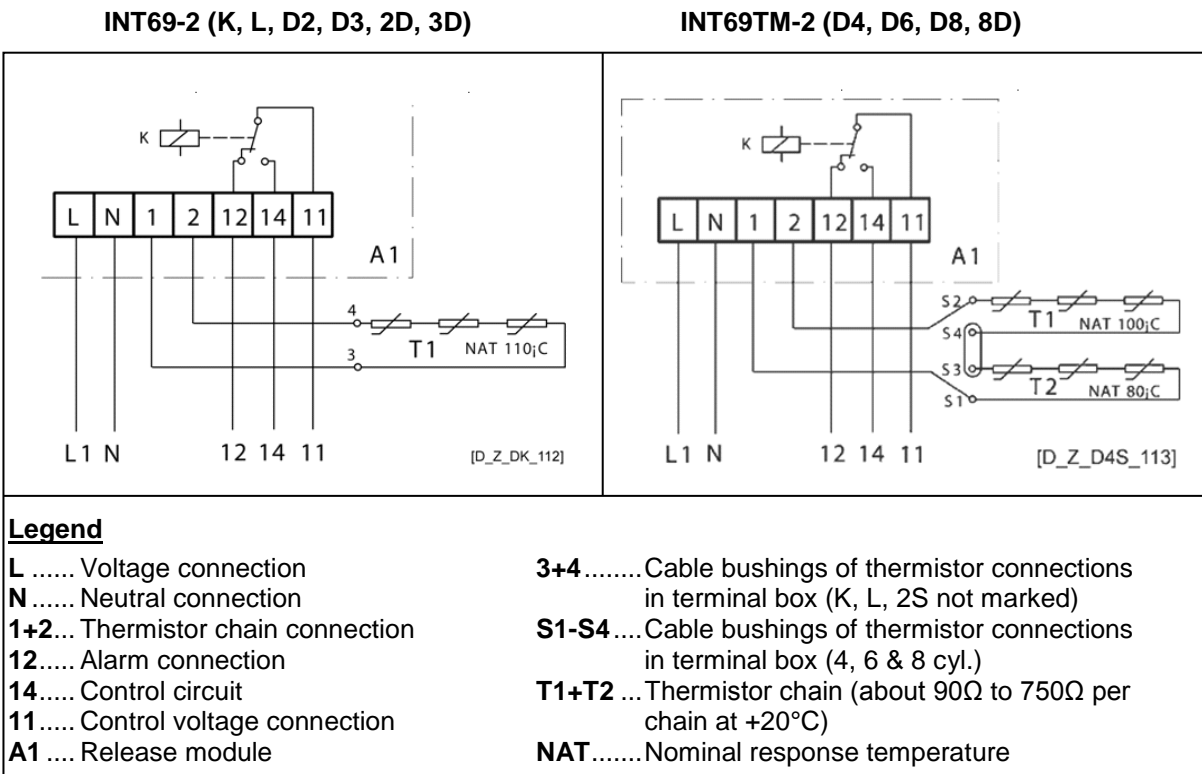
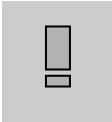

Figure 15

Protection class IP20.

**Control circuit wiring:**



**IMPORTANT**

**Different sources for power supply and contact 11-14! Module malfunction!** Use the same potential for the power supply and the switch contact of the control loop (11-14).

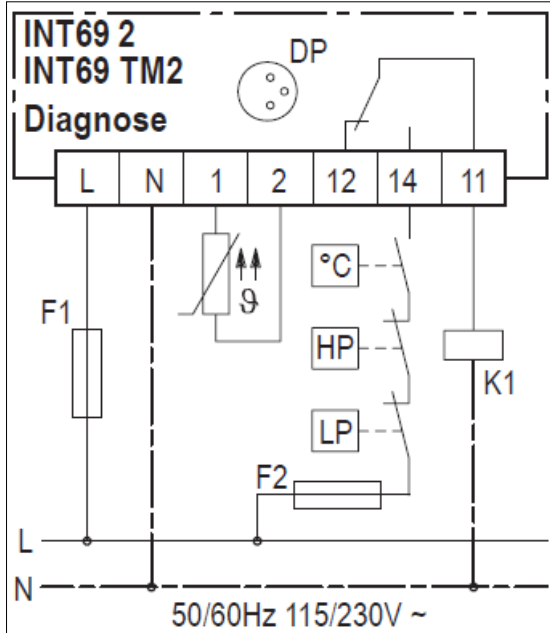

Figure 16

**4.6 Discharge temperature protection**

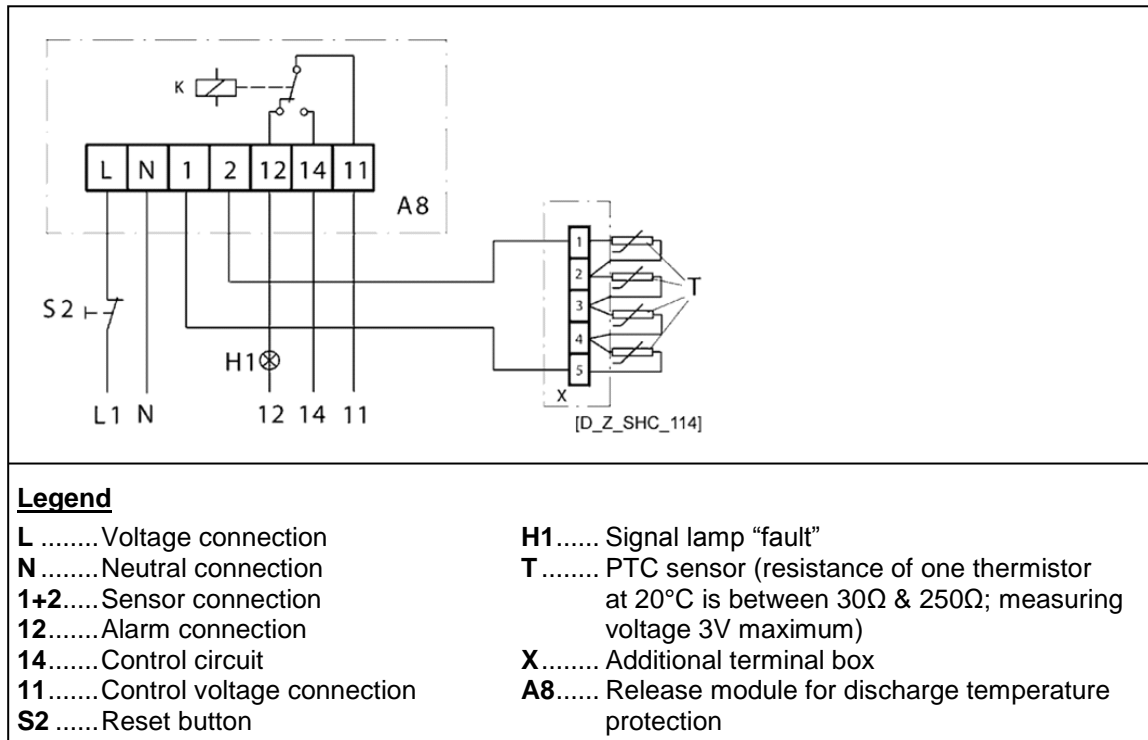

Figure 17

**Protection class IP55.**

Safety instructions

Product description

Installation

Electrical connection

Starting up & operation

Maintenance & repair

Trouble-shooting

Dismantling & disposal



## 4.7 Demand Cooling

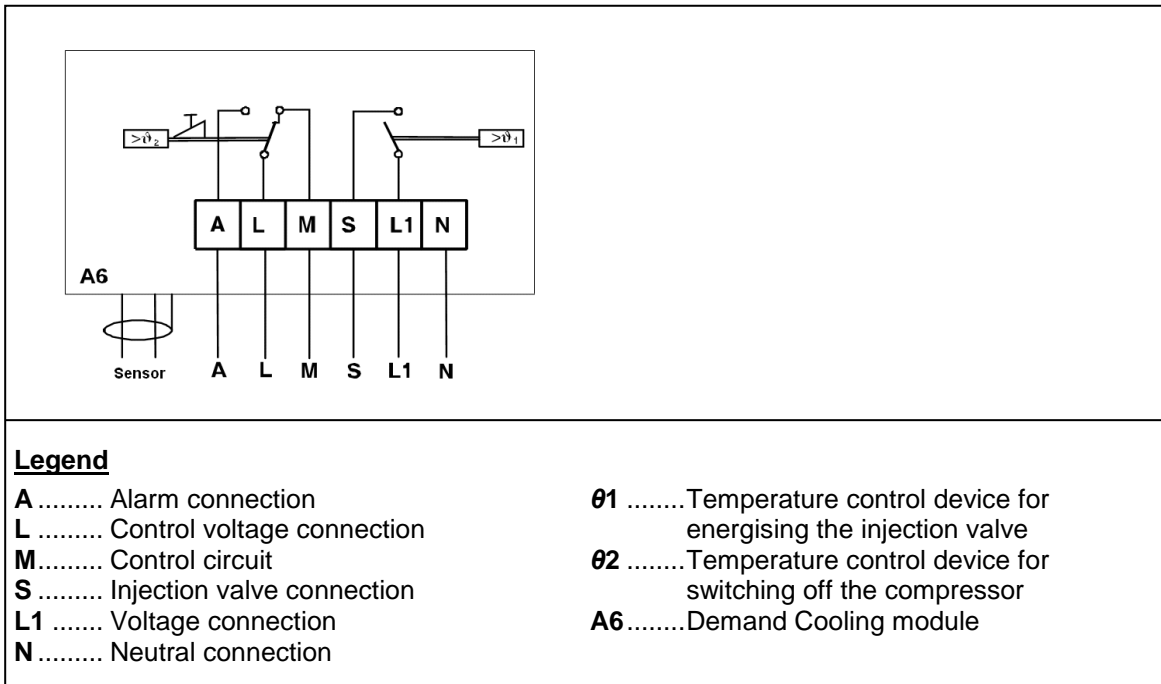

Figure 18

## 4.8 Oil pressure control

### 4.8.1 Oil pressure switch (OPS2)

Where there is a 5-wire cable connection between the electrical control panel and the compressor terminal box to the OPS module, the same wires can be applied to the OPS2 which will give the functions of an OPS1 module.

To obtain use of all of the features of the OPS2 a 7-wire cable between the electrical control cabinet and the compressor terminal box should be used. Wiring diagrams for both the OPS1 and OPS2 are shown in Technical Information D7.8.3 “DWM Copeland™ Semi-hermetic Compressor Oil Pressure Differential Switch OPS2” available at [www.emersonclimate.eu](http://www.emersonclimate.eu). The wiring diagram relates to an option using a 7-wire cable.

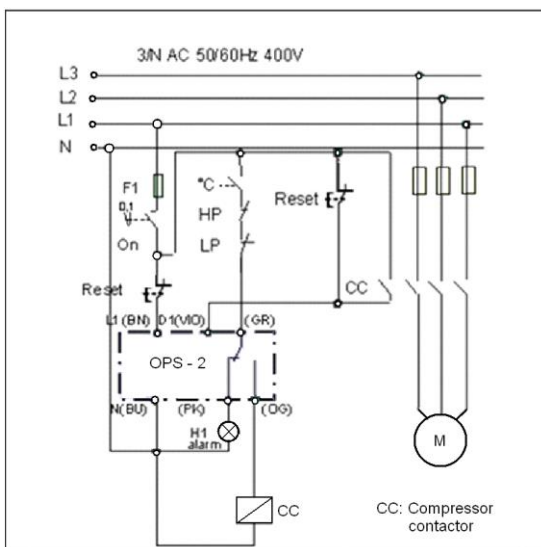

#### Wiring:

- Brown (BN) = Power supply input
- Violet (VIO) = Running signal from the compressor
- Grey (GR) = Input changeover contact from the daisy chain
- Orange (OG) = Output changeover contact linked to the compressor contactor
- Pink (PK) = Output changeover contact linked to the alarm
- Blue (BU) = Power supply output

Figure 19

**NOTE:** Where a 5- or 7-wire cable is stated a 4- or 6-wire cable is required. In some countries only a 5- or 7-wire cable is available. See more information about OPS2 in Technical Information D7.8.3 “DWM Copeland™ Semi-hermetic Compressor Oil Pressure Differential Switch OPS2”.

## 4.8.2 SENTRONIC Oil pressure control

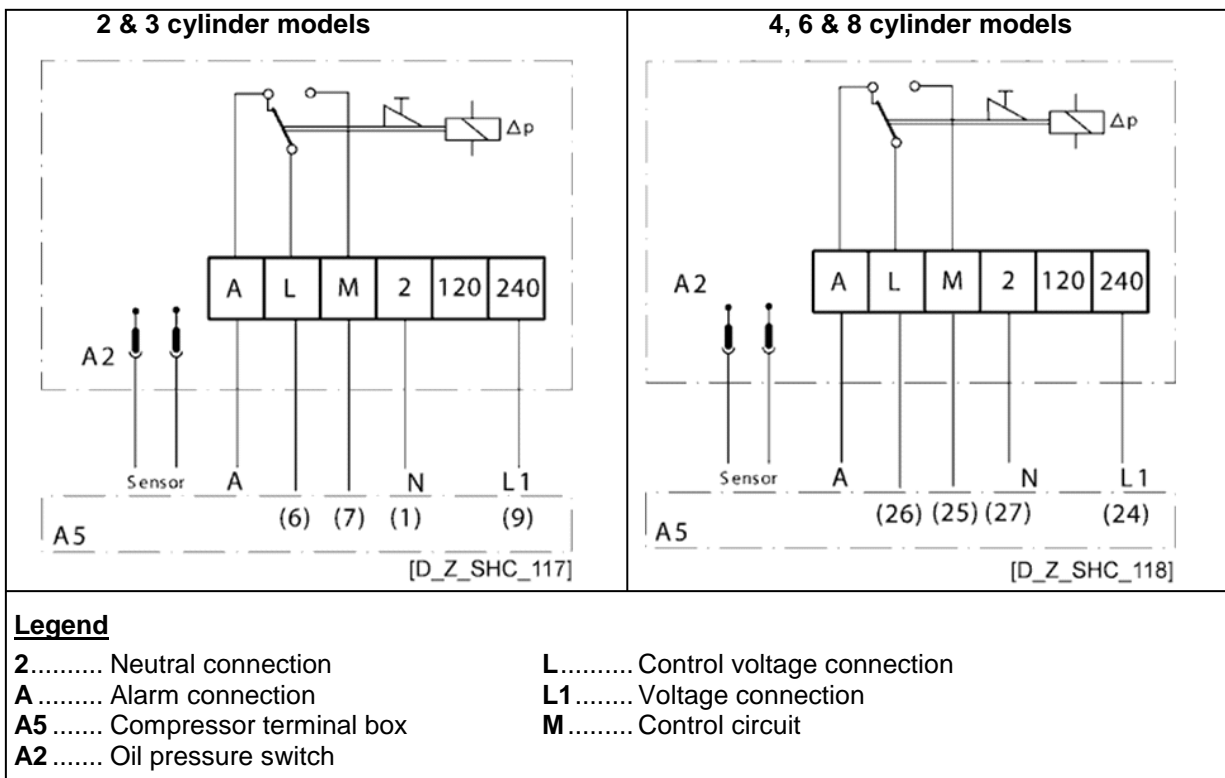

Figure 20

Protection class IP31.

## 4.8.3 Oil pressure switch – ALCO FD 113 ZU (A22 - 057)

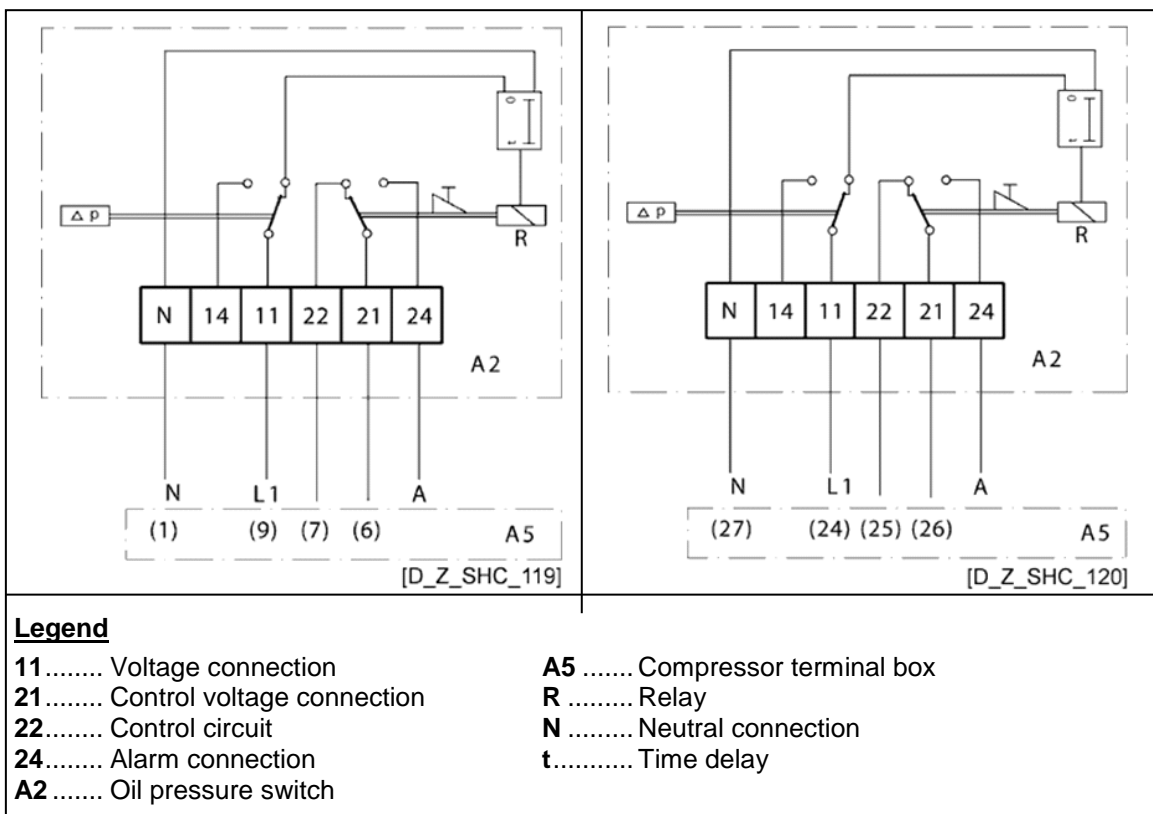

Figure 21

Protection class IP30.

Safety instructions

Product description

Installation

Electrical connection

Starting up & operation

Maintenance & repair

Trouble-shooting

Dismantling & disposal

## 4.8.4 Crankcase heaters



### IMPORTANT

**Oil dilution! Bearing malfunction!** Turn the crankcase heater on 12 hours before starting the compressor.

A crankcase heater is used to prevent refrigerant from migrating into the shell during standstill periods.

### 27-Watt heater element for K compressors

- The internal crankcase heater for K compressors is a self-regulating 27-Watt PTC heater (see **Fig. 22**).

### 70-Watt and 100-Watt heater element

- The 70-Watt heater for L, 2D and D2 compressors is screwed into a pocket.
- Heaters for D3, 3D, D4 and D6 compressors are screwed into a sleeve (see **Fig. 22**).

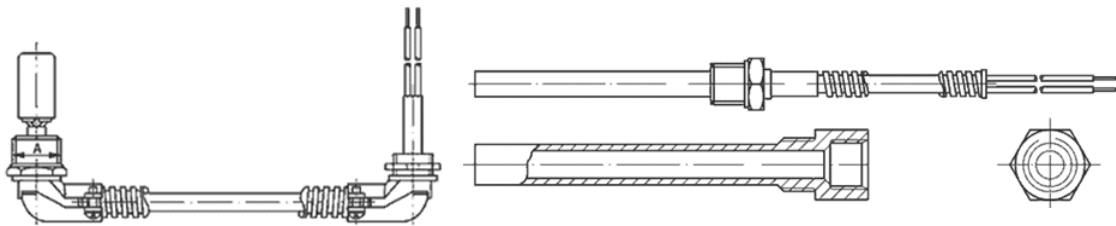

Figure 22: Crankcase heater 27W, 70W and 100W

### 200 Watt heater element

- In compressors that are equipped with a deep oil sump the heater element is inserted into a special chamber and fixed to the compressor body.

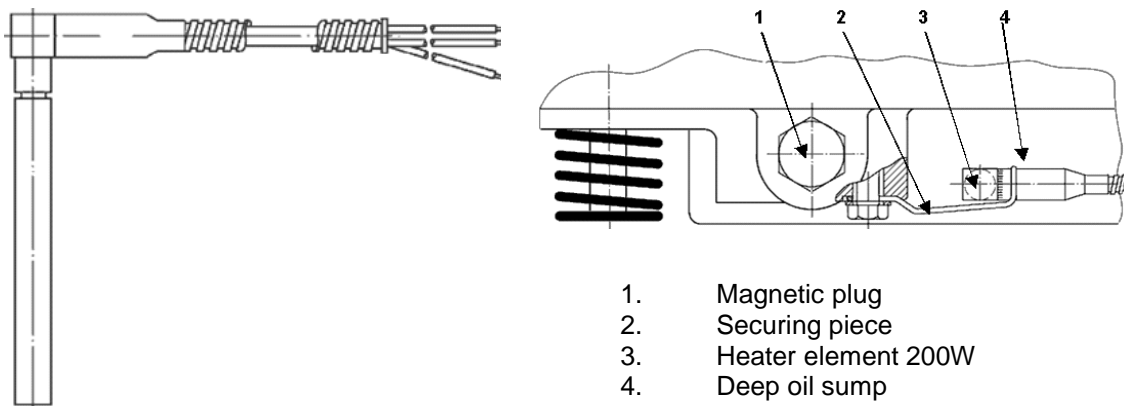

Figure 23: Crankcase heater 200W

## 5 Starting up & operation



### WARNING

**Diesel effect! Compressor destruction!** The mixture of air and oil at high temperature can lead to an explosion. Avoid operating with air.



### IMPORTANT

**Oil dilution! Bearing malfunction!** Turn the crankcase heater on 12 hours before starting the compressor.

### 5.1 Leak test

The suction shut-off valve and discharge shut-off valve on the compressor must remain closed during pressure testing to prevent air and moisture from entering the compressor. The test pressure (dried nitrogen) must not exceed 20.5 bar provided no other system component pressure is lower. In this case the lower pressure is the test pressure.

### 5.2 System evacuation

Before the installation is put into commission, it has to be evacuated with a vacuum pump. Proper evacuation reduces residual moisture to 50 ppm. The installation of adequately sized access valves at the furthest point from the compressor in the suction and liquid lines is advisable. To achieve undisturbed operation the compressor valves are closed and the system is evacuated down to 0.3 mbar / 0.225 Torr. Pressure must be measured using a vacuum pressure (Torr) gauge on the access valves and not on the vacuum pump; this serves to avoid incorrect measurements resulting from the pressure gradient along the connecting lines to the pump. Then the compressor must be evacuated.

Due to the factory holding charge of dry air the compressor is under pressure (approximately 1 to 2.5 bar); this is to indicate the compressor does not leak.

When plugs are removed from the compressor in order to connect a pressure gauge or to fill in oil, the plug may pop out under pressure and oil can spurt out.

### 5.3 Preliminary checks – Pre-starting

Discuss details of the installation with the installer. If possible, obtain drawings, wiring diagrams, etc.

It is ideal to use a check-list but always check the following:

- Visual check of the electrics, wiring, fuses etc
- Visual check of the plant for leaks, loose fittings such as TXV bulbs etc
- Compressor oil level
- Calibration of HP & LP switches and any pressure actuated valves
- Check setting and operation of all safety features and protection devices
- All valves in the correct running position
- Pressure and compound gauges fitted
- Correctly charged with refrigerant
- Compressor electrical isolator location and position

### 5.4 Charging procedure



### CAUTION

**Low suction pressure operation! Compressor damage!** Do not operate with a restricted suction. Do not operate with the low-pressure cut-out bridged. Do not use compressor to test opening set point of high-pressure cut-out.

The system should be liquid-charged through the liquid-receiver shut-off valve or through a valve in the liquid line. The use of a filter drier in the charging line is highly recommended. The majority of the charge should be placed in the high side of the system to prevent bearing washout during first-time start on the assembly line.

## 5.5 Initial start-up



### CAUTION

**Oil dilution! Bearing malfunction!** It is important to ensure that new compressors are not subjected to liquid abuse. Turn the crankcase heater on 12 hours before starting the compressor.



### CAUTION

**High discharge pressure operation! Compressor damage!** Do not use compressor to test opening set point of high-pressure cut-out.

The compressor must be equipped according to our technical documentation considering the application intended. Make sure of this before start-up.

For brazing connections where dissimilar or ferric metals are joined a silver alloy rod with a minimum of 30% silver shall be used being either flux-coated or with a separate flux.

Bolt torque settings are listed in **Appendix 2**.

With the exception of rubber coated metallic gaskets (Wolverine) all gaskets should be oiled before fitting. O-rings should also be oiled.

**NOTE: A compressor should never be operated beyond its approved application range! Check by consulting the appropriate data sheet. To avoid motor damage the compressor must neither be started, nor may high-potential testing be carried out under vacuum.**

## 5.6 Minimum run time

Emerson Climate Technologies recommends a maximum of 10 starts per hour. The most critical consideration is the minimum run time required to return oil to the compressor after start-up.

## 5.7 Recommended inverter range

Copeland compressors are released for operation with frequency variation from 25 Hz to 60 Hz.

Emerson Climate Technologies recommends the use of Control Techniques brand inverters with Copeland standard and Discus compressors.

**NOTE: For further information on operation with inverter, and for a Control Techniques inverter cross reference list, see Technical Information D7.9.2 “Use of Inverters with DWM Copeland™ Compressors” available at [www.emersonclimate.eu](http://www.emersonclimate.eu).**

## 6 Maintenance & repair

### 6.1 Exchanging the refrigerant

Qualified refrigerants and oils are given in section 2.5.1.

It is not necessary to replace the refrigerant with new unless contamination due to an error such as topping up the system with an incorrect refrigerant is suspected. To verify correct refrigerant composition, a sample can be taken for chemical analysis. A check can be made during shut down by comparing the refrigerant temperature and pressure using precision measurements at a location in the system where liquid and vapour phases are present and when the temperatures have stabilised.

In the event that the refrigerant needs replacing, the charge should be recovered using a suitable recovery unit.

### 6.2 Refrigerant retrofit from HFC to HFO/HFC blends



Beside the standard retrofitting procedures on HFC systems, when retrofitting to HFO/HFC blends, like for example R450A, R513A, it is critical to fulfil the following conditions:

- maintain adequate superheat settings
- no liquid refrigerant migration into the compressor at any time, especially during standstill, during or after defrost, or after reverse mode for example in heat pumps.

Contact Application Engineering for any further information.

### 6.3 Shut-off valves

Rotalock shut-off valves or shut-off valve bolts should be periodically re-torqued to ensure that leak prevention tightness is maintained.

### 6.4 Compressor replacement



#### CAUTION

**Inadequate lubrication! Bearing destruction!** Exchange the accumulator after replacing a compressor with a burned out motor. The accumulator oil return orifice or screen may be plugged with debris or may become plugged. This will result in starvation of oil to the new compressor and a second failure.

In the case of a motor burnout, the majority of contaminated oil will be removed with the compressor. The rest of the oil is cleaned through the use of suction and liquid line filter driers. A 100% activated alumina suction line filter drier is recommended but must be removed after 72 hours. **It is highly recommended that the suction accumulator be replaced if the system contains one.** This is because the accumulator oil return orifice or screen may be plugged with debris or may become plugged shortly after a compressor failure. This will result in starvation of oil to the replacement compressor and a second failure. When a single compressor or tandem is exchanged in the field, it is possible that a major portion of the oil may still be in the system. While this may not affect the reliability of the replacement compressor, the extra oil will add to rotor drag and increase power usage.

### 6.5 Lubrication and oil removal



#### CAUTION

**Chemical reaction! Compressor destruction!** Do not mix up ester oils with mineral oil and/or alkyl benzene when used with chlorine-free (HFC) refrigerants.

The compressor is supplied with an initial oil charge. The standard oil charge for use with refrigerants R404A, R407A, R407C, R407F, R448A, R449A, R450A, R134a and R507, is a polyolester (POE) lubricant Emkarate RL 32-3MAF. In the field the oil level could be topped up with Mobil EAL Arctic 22 CC if 3MAF is not available.

One disadvantage of POE is that it is far more hygroscopic than mineral oil (see **Figure 24**). Only brief exposure to ambient air is needed for POE to absorb sufficient moisture to make it unacceptable for use in a refrigeration system. Since POE holds moisture more readily than mineral oil it is more difficult to remove it through the use of vacuum. Compressors supplied by Emerson Climate Technologies contain oil with low moisture content, and it may rise during the system assembling process. Therefore it is recommended that a properly sized filter-drier is installed in all POE systems. This will maintain the moisture level in the oil to less than 50 ppm. If oil is charged into a system, it is recommended to use POE with moisture content no higher than 50 ppm.

The diagram below compares the hygroscopic characteristics of POE oil with mineral oil (moisture absorption in PPM at 25°C and 50% relative humidity).

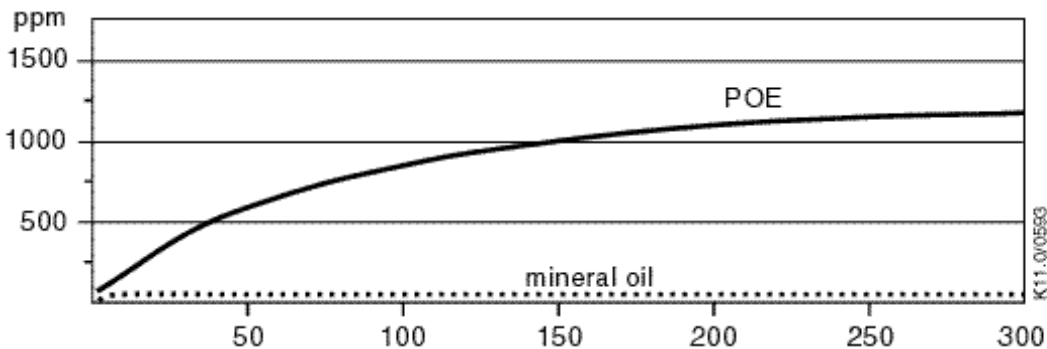

Figure 24: Absorption of moisture in ester oil in comparison to mineral oil in ppm by weight at 25°C and 50% relative humidity (h = hours)

If the moisture content of the oil in a refrigeration system reaches unacceptable high levels, corrosion and copper plating may occur. The system should be evacuated down to 0.3 mbar or lower. If there is uncertainty as to the moisture content in the system, an oil sample should be taken and tested for moisture. Sight glass/moisture indicators currently available can be used with the HFC refrigerants and lubricants; however, the moisture indicator will just show the moisture contents of the refrigerant. The actual moisture level of POE would be higher than the sight glass indicates. This is due to the high hygroscopicity of the POE oil. To determine the actual moisture content of the lubricant, samples have to be taken from the system and analysed.

## 6.6 Oil additives

Although Emerson Climate Technologies cannot comment on any specific product, from our own testing and past experience, we do not recommend the use of any additives to reduce compressor bearing losses or for any other purpose. Furthermore, the long term chemical stability of any additive in the presence of refrigerant, low and high temperatures, and materials commonly found in refrigeration systems is complex and difficult to evaluate without rigorously controlled chemical laboratory testing. The use of additives without adequate testing may result in malfunction or premature failure of components in the system and, in specific cases, in voiding the warranty on the component.

## 6.7 Unbrazing system components



### WARNING

**Explosive flame! Burning!** Oil-refrigerant mixtures are highly flammable. Remove all refrigerant before opening the system. Avoid working with an unshielded flame in a refrigerant charged system.

Before opening up a system it is important to remove all refrigerant from both the high and low sides of the system. If a brazing torch is then applied to the low side while the low side shell and suction line contain pressure, the pressurized refrigerant and oil mixture could ignite when it escapes and contacts the brazing flame. To prevent this occurrence, it is important to check both the high and low sides with manifold gauges before unbrazing. Instructions should be provided in appropriate product literature and assembly (line repair) areas. If compressor removal is required, the compressor should be cut out of system rather than unbrazed.



## 7 Troubleshooting

The prevention of failures is one of the primary responsibilities of the installer. Otherwise the user will not get the benefit of factory guaranteed quality.

### 7.1 Lubrication problems

Compressors are delivered with an initial oil charge. The correct oil level is shown in section 2.6.11.

Some, but not all lubrication problems are listed below:

- **Oil pump-out due to high on/off cycling rate.** The number of cycles should be limited to 10 - 12 per hour. A high cycling rate will pump oil into the system and lead to lubrication failure. Oil leaves the compressor at start-up and the short running time is insufficient to return the oil to the compressor via the suction side, the result being lubrication damage.
- **Incorrect calculation of pipe sizes.** It should be remembered that the entire system will be coated in oil to some extent. Oil viscosity changes with temperature. More oil stays in the system than was originally expected.
- **Low gas velocity.** System gas velocity changes depending on temperature and load (capacity control). In low load conditions the gas velocity may not be high enough to return oil to the compressor.
- **Faulty or badly designed oil return system.**
- **Incorrect pipe work.**
- **Leaks.**

In time, lubrication problems lead to failure of the main moving parts. A standard oil pressure switch protects the compressor against low oil pressure if the problem lasts for some considerable time.

The typical breakdown symptom of a compressor with inadequate lubrication is failure of the bearing furthest away from the oil supply, the nearest having just enough oil to be properly lubricated.

### 7.2 Oil dilution

During the off-cycle a certain refrigerant concentration is always present in the compressor oil. This depends on the compressor temperature and crankcase pressure. The rapid reduction of pressure on start-up causes the refrigerant to evaporate from the oil. This causes oil foaming which can be seen in the compressor oil sight glass. The oil pump draws in much diluted oil and foam and cannot build up oil pressure. If this cycle is repeated often enough bearing failure will eventually occur. To prevent this type of failure a crankcase heater and/or a pump down system should be fitted.

### 7.3 Refrigerant migration

When the compressor is switched off for a long period refrigerant can condense in the crankcase. Example: R22 with a crankcase pressure of 8.03 bar and a temperature of 22°C, the crankcase would contain a mixture of 35% R22 and 65% oil by weight. If the compressor body is colder than the evaporator, refrigerant will move from the evaporator to the compressor crankcase. Refrigerant migration normally occurs when the compressor is installed in a cold area. A crankcase heater and/or a pump down cycle provide good protection against refrigerant migration.

### 7.4 Inadequate suction superheat

The suction superheat should not fall below 10K. Low superheat will cause valve plate, piston, cylinder wall and connecting rod damage. Low superheat can be caused by a defective or badly adjusted expansion valve, incorrect sensor bulb mounting or by very short refrigeration lines. If refrigeration lines are very short the installation of a heat exchanger or an accumulator would be recommended.



## 7.5 Acid formation

Acid forms in the presence of moisture, oxygen, metal salts and metal oxides, and/or high discharge temperatures. The chemical reactions are accelerated at higher temperatures. Oil and acid react with each other. Acid formation leads to damage of the moving parts and in extreme cases to motor burn-out. Several different test methods can be used to test for acid formation. If acid is present, a complete oil change (including the oil in the oil separator) will help. A suction filter that removes acid should also be fitted. Check filter-drier condition.

## 7.6 Inadequate compressor cooling

Cooling fans must be fitted on certain compressor models. If the fan does not provide sufficient cooling high discharge temperatures can result. The only solution is to fit an appropriate cooling fan.

## 7.7 High discharge temperatures

The limit is 120°C measured on the discharge line a few centimetres from the service valve. Symptoms of high discharge temperatures are cutting-out on the high pressure switch (dirty condenser), oil carbonisation, black oil and acid formation. Inadequate lubrication is the result. The condenser should be cleaned regularly. The evaporating temperature should not be allowed to fall below the application limit of the compressor.

## 7.8 Motor burnout due to undersized contactors

If contactors are undersized the contacts can weld. Complete motor burnout on all three phases despite the presence of a functioning protection system can be the result. If the application point of a compressor is changed the contactor sizing should be rechecked.

## 7.9 Motor burnout due to by-passed or disconnected protectors

If large sections of the windings are burned out, it must be assumed that the protector was either not connected or by-passed.

## 8 Dismantling & disposal

---



**Removing oil and refrigerant:**  
**Do not disperse in the environment.**  
**Use the correct equipment and method of removal.**  
**Dispose of oil and refrigerant properly.**  
**Dispose of compressor properly.**

## Appendix 1 – Compressor connections

### Standard compressor connections

#### DK / K

DKM-5*	KM-5*	DKJ-7*	KJ-7*	DKSJ-10*	KSJ-10*	DKSL-15*	KSL-15*
DKM-7*	KM-7*	DKJ-10*	KJ-10*	DKSJ-15*	KSJ-15*	DKSL-20*	KSL-20*
DKM-10*	KM-10*	DKJ-15*	KJ-15*	DKL-15*	KL-15*	DKL-20*	KL-20*

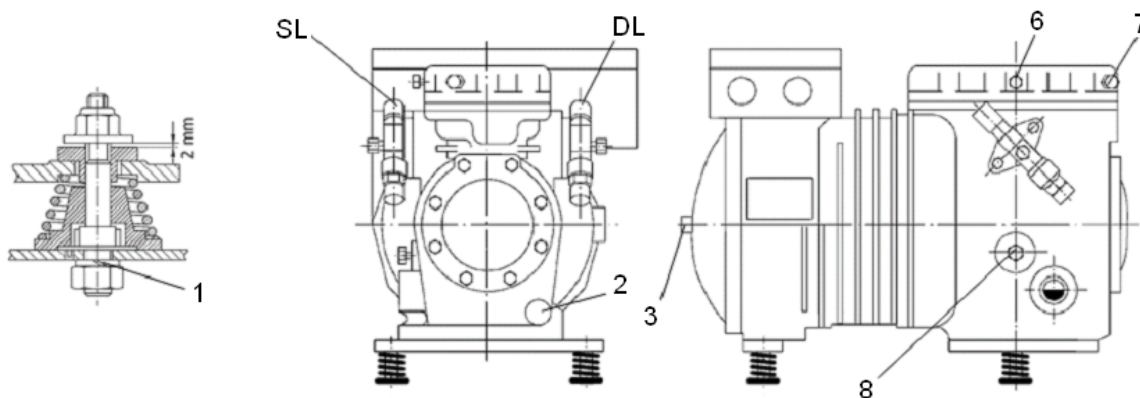

SL	Suction line (sweat)	Ø 1/2"	DL	Discharge line (sweat)	Ø 1/2"
1	Base mountings	Ø 11 mm	6	Plug low pressure connection	1/8" - 27 NPTF
2	Pocket for heater with plug	M25 x 1.5	7	Plug high pressure connection	1/8" - 27 NPTF
3	Magnetic plug	1/8" - 27 NPTF	8	Plug oil charge	1/8" - 27 NPTF

#### DL / L

DLE-20*	LE-20*	DLJ-20*	LJ-20*	DLL-40*	LL-40*
DLF-20*	LF-20*	DLJ-30*	LJ-30*	DLSG-40*	LSG-40*
DLF-30*	LF-30*	DLL-30*	LL-30*		

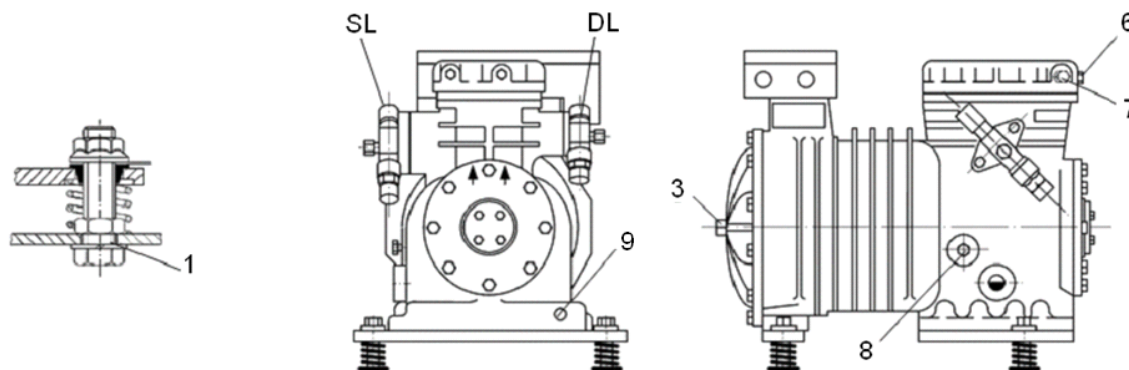

SL	Suction line (sweat)	Ø 1/2"	DL	Discharge line (sweat)	Ø 1/2"
1	Base mountings	Ø 14 mm	7	Plug low pressure connection	1/8" - 27 NPTF
3	Magnetic plug	1/8" - 27 NPTF	8	Plug oil charge	1/8" - 18 NPTF
6	Plug high pressure connection	1/8" - 27 NPTF	9	Pocket for heater with plug	3/8" - 18 NPSL

## DLH / LH

DLHA-50\*

LHA-50\*

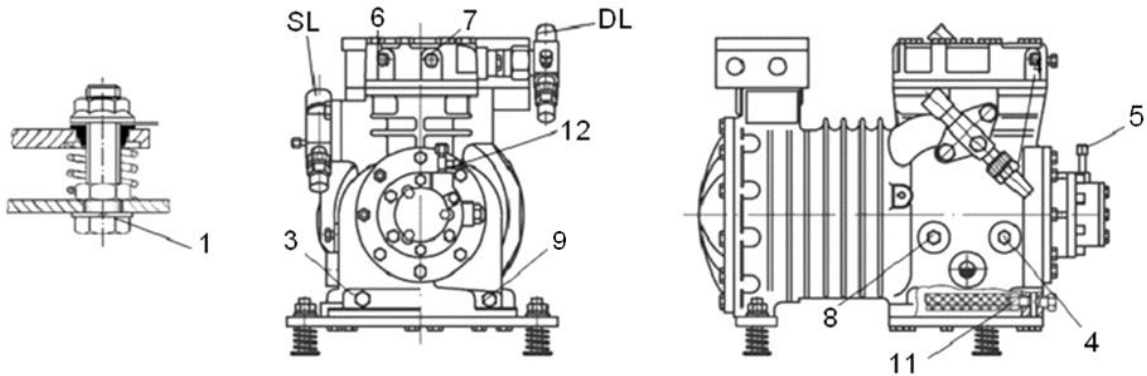

SL	Suction line (sweat)	Ø 1 1/8"	DL	Discharge line (sweat)	Ø 7/8"
1	Base mountings	Ø 12 mm	7	Plug high pressure connection	1/8" - 27 NPTF
3	Magnetic plug	3/8" - 18 NPTF	8	Plug oil charge	1/4" - 18 NPTF
4	Plug oil pressure control LP	1/4" - 18 NPTF	9	Pocket for heater with plug	3/8" - 18 NPSL
5	Connection oil pressure control HP	1/4" - 6 mm	11	Oil screen built-in	-
6	Plug low pressure connection	1/8" - 27 NPTF	12	Oil pressure connection, Schraeder	1/4" - 6 mm

## D2S

D2SA-45\*

D2SC-55\*

D2SK-65\*

D2SA-55\*

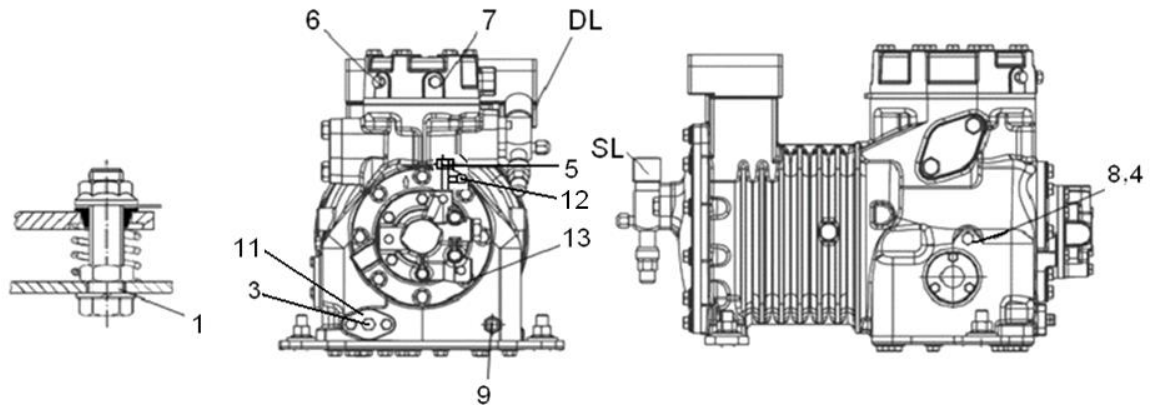

SL	Suction line (sweat)	Ø 1 1/8"	DL	Discharge line (sweat)	Ø 7/8"
1	Base mountings	Ø 14 mm	8	Plug oil charge	1/4" - 18 NPTF
3	Magnetic plug	1/8" - 27 NPTF	9	Pocket for heater with plug	3/8" - 18 NPSL
4	Plug oil pressure control LP	1/4" - 18 NPTF	11	Oil screen built-in	
5	Connection oil pressure control HP	1/4" - 6 mm	12	Oil pressure connection, Schraeder	1/4" - 6 mm
6	Plug low pressure connection	1/8" - 27 NPTF	13	Sensor connection OPS	
7	Plug high pressure connection	1/8" - 27 NPTF			

## D3S

D3SA-75\*

D3SC-75\*

D3SS-100\*

D3SC-100\*

D3SS-150\*

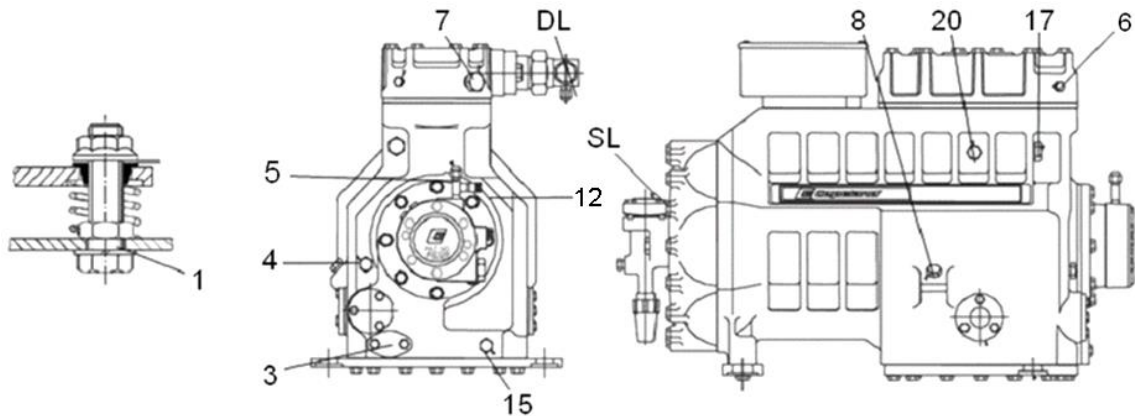

SL	Suction line (sweat) D3SA-75*, D3SC-75* D3SC-100*, D3SS-100*	Ø 1 3/8"	SL	Suction line (sweat) D3SS-150*	Ø 1 5/8"
DL	Discharge line (sweat)	Ø 1 1/8"	7	Plug high pressure connection	1/2" - 14 NPTF
1	Base mountings	Ø 18 mm	8	Plug oil charge	1/4" - 18 NPTF
3	Magnetic plug	1/8" - 27 NPTF	12	Oil pressure connection, Schraeder	7/16" - UNF
4	Plug oil pressure control LP	1/4" - 18 NPTF	15	Sleeve (crankcase heater)	3/8" - 18 NPSL
5	Connection oil pressure control HP	1/4" - 6 mm	17	Plug low pressure connection	1/2" - 14 NPTF
6	Plug low pressure connection	1/8" - 27 NPTF	20	DTC valve plug connection	1/8" - 27 NPTF

## D4S

D4SA-100\*

D4SF-100\*

D4SH-150\*

D4SJ-200\*

D4SL-150\*

D4ST-200\*

D4SA-200\*

D4SH-250\*

D4SJ-300\*

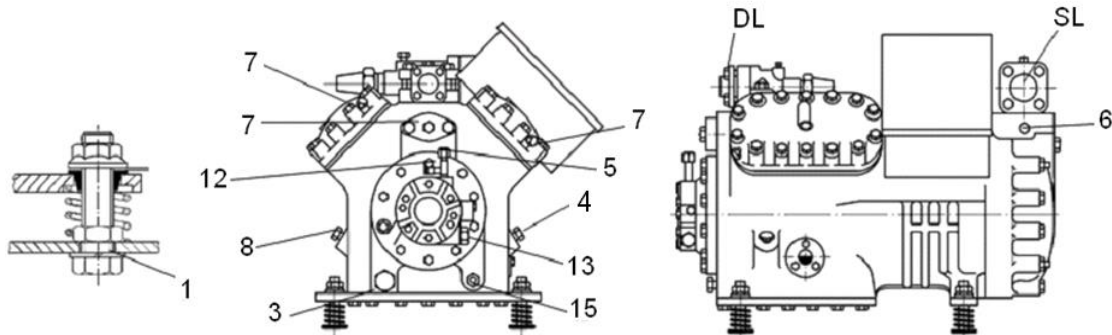

SL	Suction line (sweat) D4SF-100*, D4SL-150*, D4SA-100*, D4SA-200*, D4SH-150*	Ø 1 5/8"	DL	Discharge line (sweat) D4SF-100*, D4SL-150*, D4SA-100*, D4SH-150*, D4SA-200*, D4SH-250*	Ø 1 1/8"
SL	Suction line (sweat) D4ST-200*, D4SJ-200*, D4SH-250*, D4SJ-300*	Ø 2 1/8"	DL	Discharge line (sweat) D4ST-200*, D4SJ-200*, D4SJ-300*	Ø 1 3/8"
1	Base mountings	Ø 18 mm	7	Plug high pressure connection	1/8" - 27 NPTF
3	Magnetic plug	1" - 16 UN	8	Plug oil charge	1/4" - 18 NPTF
4	Plug oil pressure control LP	1/4" - 18 NPTF	12	Oil pressure connection, Schraeder	1/4" - 6 mm
5	Connection oil pressure control HP	1/4" - 6 mm	13	Sensor connection OPS	
6	Plug low pressure connection	1/8" - 27 NPTF	15	Sleeve (crankcase heater)	1/2" - 14 NPSL

## D6S

D6SA-300\*

D6SF-200\*

D6SH-200\*

D6SL-250\*

D6ST-320\*

D6SH-350\*

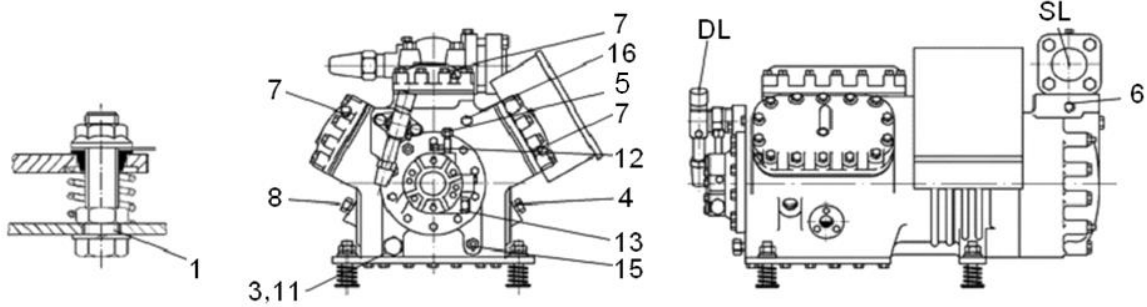

SL	Suction line (sweat)	Ø 2 1/8"	DL	Discharge line (sweat)	Ø 1 3/8"
1	Base mountings	Ø 18 mm	8	Plug oil charge	1/4" - 18 NPTF
3	Magnetic plug	1" - 16 UN	11	Oil screen built-in	-
4	Plug oil pressure control LP	1/4" - 18 NPTF	12	Oil pressure connection, Schraeder	1/4" - 6 mm
5	Connection oil pressure control HP	1/4" - 6 mm	13	Sensor connection OPS	
6	Plug low pressure connection	1/8" - 27 NPTF	15	Sleeve (crankcase heater)	1/2" - 14 NPSL
7	Plug high pressure connection	1/8" - 27 NPTF	16	Plug high pressure connection	1/4" - 18 NPTF

## D6SJ

D6SJ-300\*

D6SJ-400\*

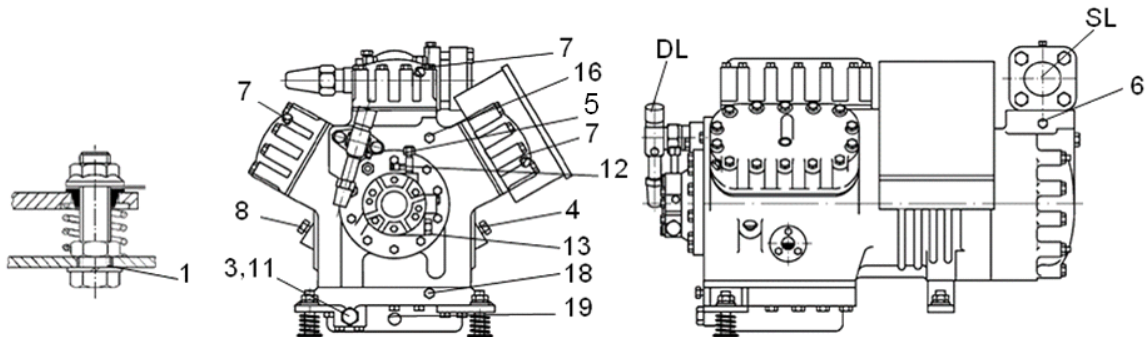

SL	Suction line (sweat)	Ø 2 1/8"	DL	Discharge line (sweat)	Ø 1 3/8"
1	Base mountings	Ø 18 mm	11	Oil screen built-in	
3	Magnetic plug	1" - 16 UN	12	Oil pressure connection, Schraeder	1/4" - 6 mm
4	Plug oil pressure control LP	1/4" - 18 NPTF	13	Sensor connection OPS	
5	Connection oil pressure control HP	1/4" - 6 mm	16	Plug high pressure connection	1/4" - 18 NPTF
6	Plug low pressure connection	1/8" - 27 NPTF	18	Plug crankcase heater	1/2" - 18 NPTF
7	Plug high pressure connection	1/8" - 27 NPTF	19	Bore crankcase heater	Ø 1/2"
8	Plug oil charge	1/4" - 18 NPTF			



## D6SK

D6SK-400\*    D6SU-400\*    D6SK-500\*

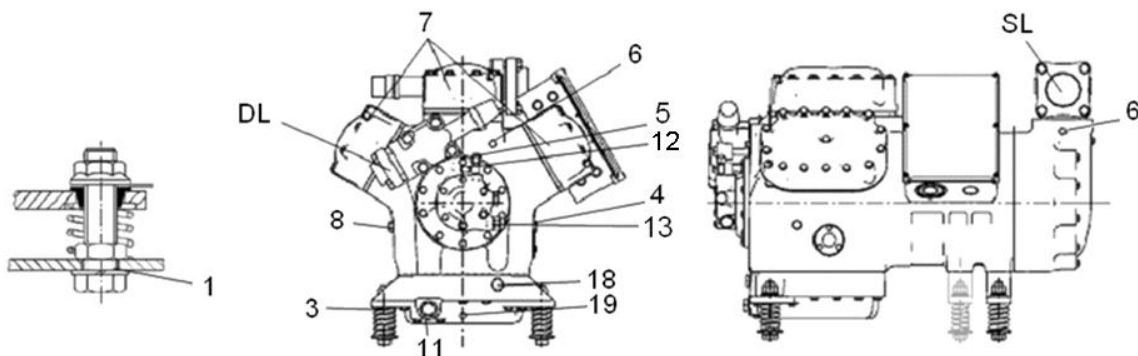

SL	Suction line (sweat)	Ø 2 1/8"	DL	Discharge line (sweat)	Ø 1 3/8"
1	Base mountings	Ø 18 mm	8	Plug oil charge	1/4" - 18 NPTF
3	Magnetic plug	1" - 16 UN	11	Oil screen built-in	
4	Plug oil pressure control LP	1/4" - 18 NPTF	12	Oil pressure connection, Schraeder	7/16" - UNF
5	Connection oil pressure control HP	1/4" - 6 mm	18	Plug crankcase heater	1/2" - 14 NPTF
6	Plug low pressure connection	1/8" - 27 NPTF	19	Bore crankcase heater	Ø 1/2"
7	Plug high pressure connection	1/8" - 27 NPTF			

## D8S

D8SH-370\*    D8SH-400\*    D8SH-500\*  
 D8SJ-450\*    D8SJ-500\*    D8SJ-600\*  
 D8SK-600\*    D8SK-700\*

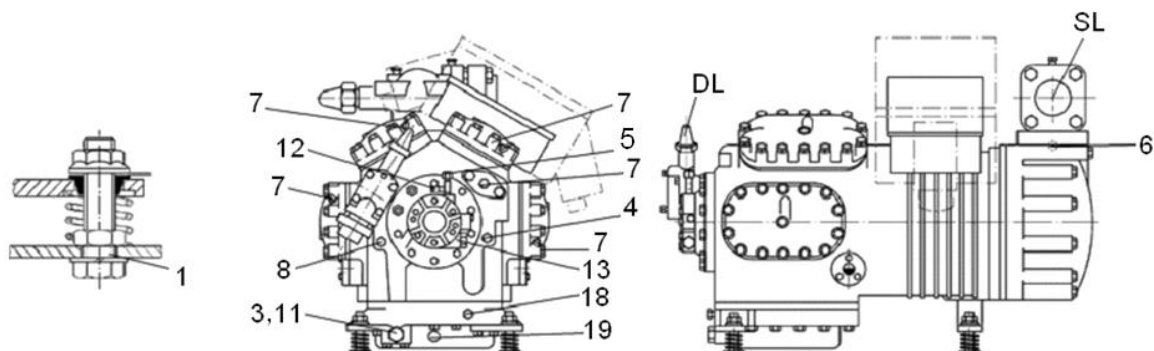

SL	Suction line (sweat) D8SH-370*, D8SH-400*, D8SH-500*	Ø 2 5/8"	DL	Discharge line (sweat) D8SH-370*, D8SH-400*, D8SH-500*, D8SJ-450*, D8SJ-500*, D8SJ-600*	Ø 1 5/8"
SL	Suction line (sweat) D8SJ-450*, D8SJ-500*, D8SJ-600*, D8SK-600*, D8SK-700*	Ø 3 1/8"	DL	Discharge line (sweat) D8SK-600*, D8SK-700*	Ø 2 1/8"
1	Base mountings	Ø 18 mm	8	Plug oil charge	1/4" - 18 NPTF
3	Magnetic plug	1" - 16 UN	12	Oil pressure connection, Schraeder	1/4" - 6 mm
4	Plug oil pressure control LP	1/4" - 18 NPTF	13	Sensor connection OPS	
5	Connection oil pressure control HP	1/4" - 6 mm	18	Plug crankcase heater	1/2" - 14 NPTF
6	Plug low pressure connection	1/8" - 27 NPTF	19	Bore crankcase heater	Ø 1/2"
7	Plug high pressure connection	1/8" - 27 NPTF			

## D6T / 6T

D6TA-150\*

6TA-150\*

D6TH-200\*

6TH-200\*

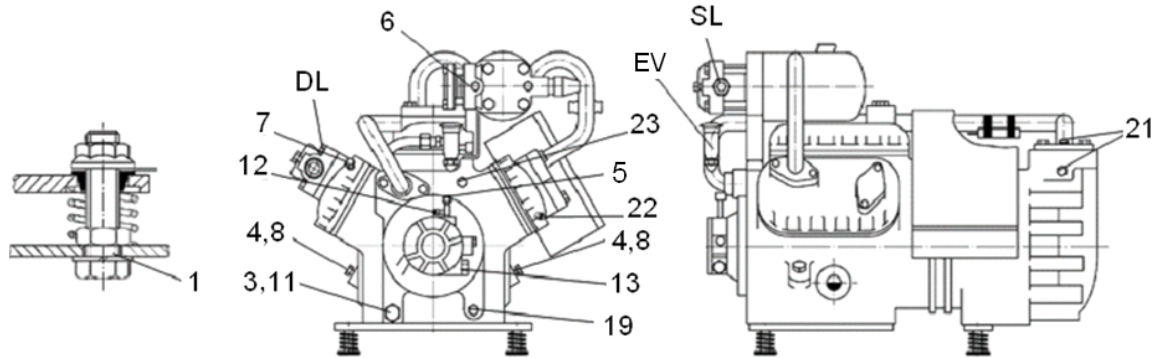

SL	Suction line (sweat)	Ø 1 5/8"	DL	Discharge line (sweat)	Ø 1 3/8"
EV	De-superheating expansion valve		11	Oil screen built-in	
1	Base mountings	Ø 18 mm	12	Oil pressure connection, Schraeder	1/4" - 6 mm
3	Magnetic plug	1" - 16 UN	13	Sensor connection OPS	
4	Plug oil pressure control LP	1/4" - 18 NPTF	19	Bore crankcase heater	Ø 1/2"
5	Connection oil pressure control HP	1/4" - 6 mm	21	Intermediate pressure connection	1/4" ≈ 6 mm Schraeder
6	Plug low pressure connection	1/4" - 18 NPTF	22	Intermediate pressure connection	1/8" - 27 NPTF
7	Plug high pressure connection	1/8" - 27 NPTF	23	Plug intermediate pressure connection	1/4" - 18 NPTF
8	Plug oil charge	1/4" - 18 NPTF			

## D6TJ / 6TJ

D6TJ-250\*

6TJ-250\*

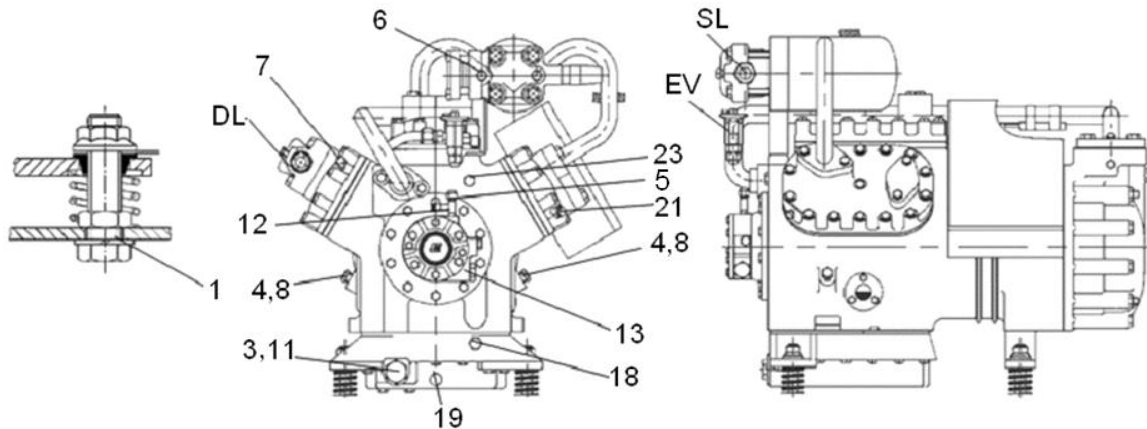

SL	Suction line (sweat)	Ø 1 5/8"	DL	Discharge line (sweat)	Ø 1 3/8"
EV	De-superheating expansion valve		11	Oil screen built-in	
1	Base mountings	Ø 18 mm	12	Oil pressure connection, Schraeder	1/4" - 6 mm
3	Magnetic plug	1" - 16 UN	13	Sensor connection OPS	
4	Plug oil pressure control LP	1/4" - 18 NPTF	18	Plug crankcase heater	1/2" - 14 NPTF
5	Connection oil pressure control HP	1/4" - 6 mm	19	Bore crankcase heater	Ø 1/2"
6	Plug low pressure connection	1/4" - 18 NPTF	21	Intermediate pressure connection	1/4" ≈ 6 mm Schraeder
7	Plug high pressure connection	1/8" - 27 NPTF	23	Plug intermediate pressure connection	1/4" - 18 NPTF
8	Plug oil charge	1/4" - 18 NPTF			

## Discus compressor connections

### D2D / 2D

D2DC-50*	2DC-50*	D2DD-50*	2DD-50*
D2DL-40*	2DL-40*	D2DB-50*	2DB-50*
D2DL75*	2DL75*	D2DB-75*	2DB-75*

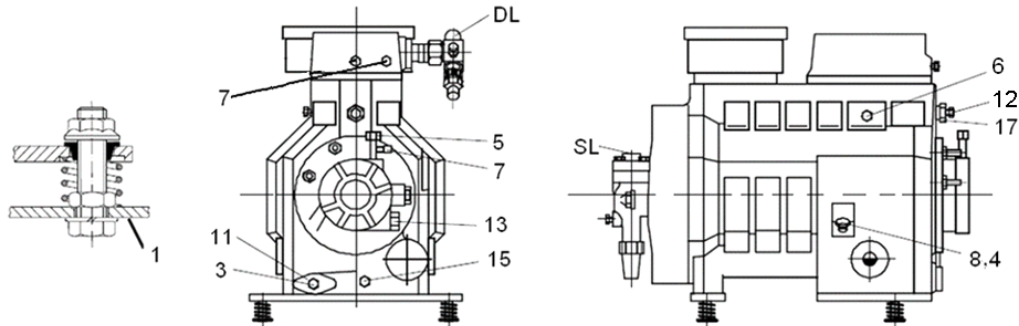

DL	Discharge line size (sweat) D2DC-50*, D2DD-50*, D2DL-40*, D2DB-50*	Ø 7/8"	DL	Discharge line size (sweat) D2DL-75*, D2DB-75*	Ø 1 1/2"
SL	Suction line size (sweat)	Ø 1 3/8"	8	Plug oil charge	1/4" - 18 NPTF
1	Base mountings	Ø 14 mm	11	Oil screen built-in	
3	Magnetic plug	1/8" - 27 NPTF	12	Oil pressure connection, Schraeder	7/16" - UNF
4	Plug oil-pressure control LP	1/4" - 18 NPTF	13	Sensor connection OPS	
5	Connection oil pressure control HP	1/4" - 6 mm	15	Sleeve (crankcase heater)	3/8" - 18 NPSL
6	Plug low pressure connection	1/8" - 27 NPTF	17	Plug low pressure connection	1/2" - 14 NPTF
7	Plug high pressure connection	1/8" - 27 NPTF			

### D3D / 3D

D3DA-50*	3DA-50*	D3DC-75*	3DC-75*	D3DS-100*	3DS-100*
D3DA-75*	3DA-75*	D3DC-100*	3DC-100*	D3DS-150*	3DS-150*

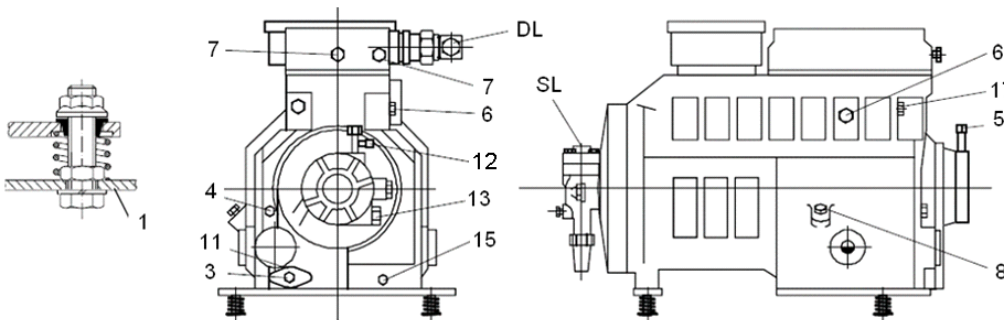

SL	Suction line size (sweat) D3DA 50*, D3DA 75*, D3DC 75*, D3DC 100*, D3DS 100*	Ø 1 3/8"	DL	Discharge line size (sweat) D3DA 50*	Ø 7/8"
SL	Suction line size (sweat) D3DS 150*	Ø 1 5/8"	DL	Discharge line size (sweat) D3DA 75*, D3DC 75*, D3DC 100*, D3DS 100*, D3DS 150*	Ø 1 1/8"
1	Base mountings	Ø 14 mm	8	Plug oil charge	1/8" - 18 NPTF
3	Magnetic plug	1/8" - 27 NPTF	11	Oil screen built-in	
4	Plug oil pressure control LP	1/4" - 18 NPTF	12	Oil Pressure connection, Schraeder	7/16" - UNF
5	Connection oil pressure control HP	1/4" - 6 mm	13	Sensor connection OPS	
6	Plug low pressure connection	1/8" - 27 NPTF	15	Sleeve (crankcase heater)	3/8" - 18 NPSL
7	Plug high-pressure connection	1/8" - 27 NPTF	17	Plug low-pressure connection	1/2" - 14 NPTF



## D4D

D4DA-100\*    D4DF-100\*    D4DH-150\*    D4DJ-200\*    D4DL-150\*    D4DT-220\*  
 D4DA-200\*                      D4DH-250\*    D4DJ-300\*

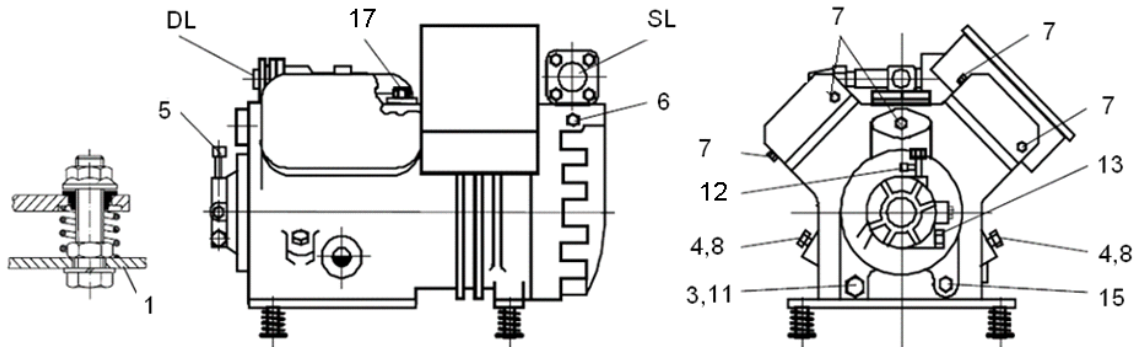

SL	Suction line size (sweat) D4DA-100*, D4DF-100*, D4DH-150*, D4DL-150*, D4DA-200*	Ø 1 5/8"	DL	Discharge line size (sweat) D4DA-100*, D4DF-100*, D4DH-150*, D4DL-150*, D4DA-200*, D4DH-250*	Ø 1 1/8"
SL	Suction line size (sweat) D4DH-250*, D4DJ-200*, D4DT-220*, D4DJ-300*	Ø 2 1/8"	DL	Discharge line size (sweat) D4DJ-200*, D4DT-220*, D4DJ-300*	Ø 1 3/8"
1	Base mountings	Ø 18 mm	8	Plug oil charge	1/4" - 18 NPTF
3	Magnetic plug	1" - 16 UN	11	Oil screen built-in	
4	Plug oil-pressure control LP	1/4" - 18 NPTF	12	Oil pressure connection, Schraeder	7/16" - UNF
5	Connection oil pressure control HP	1/4" - 6 mm	13	Sensor connection OPS	
6	Plug low pressure connection	1/8" - 27 NPTF	15	Sleeve (crankcase heater)	1/2" - 14 NPSL
7	Plug high pressure connection	1/8" - 27 NPTF	17	Plug low pressure connection	3/8" - 18 NPTF

## D6D

D6DH-200\*    D6DL-270\*    D6DH-350\*

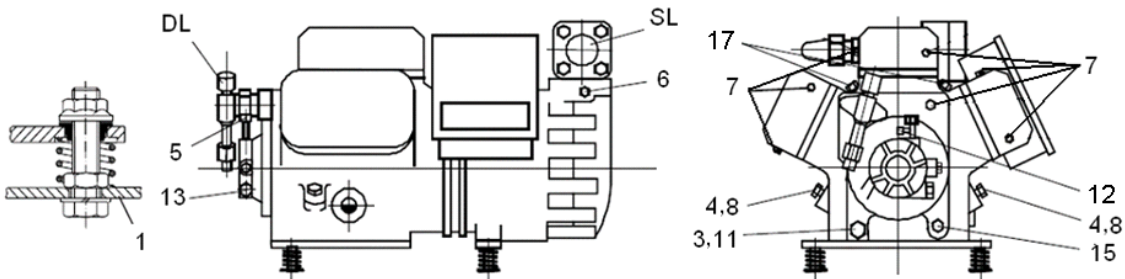

SL	Suction line size (sweat)	Ø 2 1/8"	DL	Discharge line size (sweat)	Ø 1 3/8"
1	Base mountings	Ø 18 mm	8	Plug oil charge	1/4" - 18 NPTF
3	Magnetic plug	1" - 16 UN	11	Oil screen built-in	
4	Plug oil-pressure control LP	1/4" - 18 NPTF	12	Oil pressure connection, Schraeder	7/16" - UNF
5	Connection oil pressure control HP	1/4" - 6 mm	13	Sensor connection OPS	
6	Plug low pressure connection	1/8" - 27 NPTF	15	Sleeve (crankcase heater)	1/2" - 14 NPSL
7	Plug high pressure connection	1/8" - 27 NPTF	17	Plug low pressure connection	3/8" - 18 NPTF

## D6D

D6DJ-300\*

D6DT-300\*

D6DJ-400\*

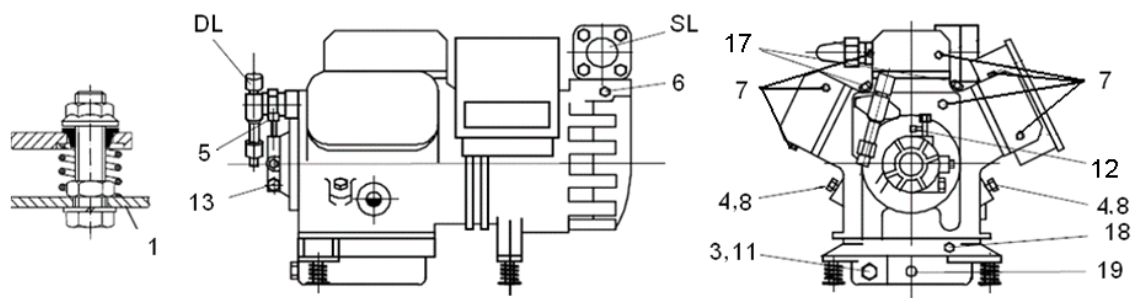

SL	Suction line size (sweat)	Ø 2 1/8"	DL	Discharge line size (sweat)	Ø 1 3/8"
1	Base mountings	Ø 18 mm	11	Oil screen built-in	
3	Magnetic plug	1" - 16 UN	12	Oil pressure connection, Schraeder	7/16" - UNF
4	Plug oil pressure control LP	1/4" - 18 NPTF	13	Sensor connection OPS	
5	Connection oil pressure control HP	1/4" - 6 mm	17	Plug low pressure connection	3/8" - 18 NPTF
6	Plug low pressure connection	1/8" - 27 NPTF	18	Plug crankcase heater	1/2" - 14 NPTF
7	Plug high pressure connection	1/8" - 27 NPTF	19	Bore crankcase heater	Ø 1/2"
8	Plug oil charge	1/4" - 18 NPTF			

## D8D / 8D

D8DL-370\*

8DL-370\*

D8DH-500\*

8DH-500\*

D8DT-450\*

8DT-450\*

D8DJ-600\*

8DJ-600\*

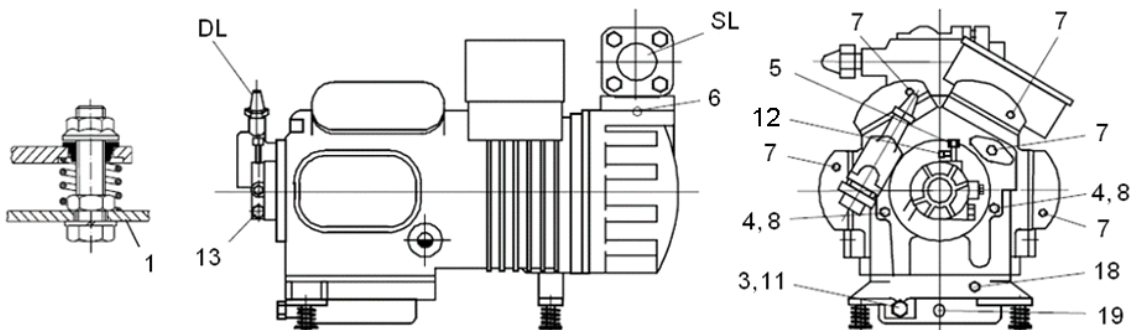

SL	Suction line size (sweat) D8DL-370*, D8DH-500*	Ø - 2 5/8"	SL	Suction line size (sweat) D8DT-450*, D8DJ-600*	Ø - 3 1/8"
DL	Discharge line size (sweat)	Ø 1 5/8"	8	Plug oil charge	1/4" - 18 NPTF
1	Base mountings	Ø 18 mm	11	Oil screen built-in	
3	Magnetic plug	1" - 16 UN	12	Oil pressure connection, Schraeder	7/16" - UNF
4	Plug oil-pressure control LP	1/4" - 18 NPTF	13	Sensor connection OPS	
5	Connection oil pressure control HP	1/4" - 6 mm	18	Plug crankcase heater	1/2" - 14 NPTF
6	Plug low pressure connection	1/8" - 27 NPTF	19	Bore crankcase heater	Ø 1/2"
7	Plug high pressure connection	1/8" - 27 NPTF			

## Appendix 2 - Tightening torques (Nm)

	DK K	DL, DLH L, LH	D2S	D2D 2D	D3S, D3D 3D	D4S, D4D	D6S, D6D D6T, 6T	D8S, D8D 8D	D8SK
Suction shut-off valve	5/16"-18 UNC 30 - 37 Nm SW 12.7	1/2"-13 UNC 46 - 56 Nm SW 19	1/2"-13 UNC 69 - 85 Nm SW 19		1/2"-13 UNC 53 - 84 Nm SW 19 5/8"-11 UNC 104 - 164 Nm SW 23.8		5/8"-11 UNC 104 - 164 Nm SW 23.8		
Discharge shut-off valve <sup>1)</sup>	5/16"-18 UNC 30 - 37 Nm SW 12.7		5/16"-18 UNC 33 - 39 Nm SW 12.7	1/2"-13 UNC 53 - 84 Nm SW 19		1/2"-13 UNC 53 - 84 Nm SW 19			5/8"-11 UNC 104 - 164 Nm SW 23.8
Rotalock nut	---	---	1 1/4"-12 UNF 30-40 Nm SW 36	1 3/4"-12 UNF 41- 54 Nm SW 50		1 3/4"-12 UNF 41 - 54 Nm SW 50		---	
Plug 3, 6, 7, 8 (DK only)	1/8"-27 NPTF 19 - 30 Nm SW 12.7		1/8"-27 NPTF 19 - 30 Nm SW 12.7			1/8"-27 NPTF 19 - 30 Nm SW 12.7			
Plug 4, 8, 16	---	1/4"-18 NPTF 27 - 50 Nm SW 17.5	1/4"-18 NPTF 27 - 50 Nm SW 17.5			1/4"-18 NPTF 27 - 50 Nm SW 17.5			
Plug 17	---	---	1/2" - 14 NPTF 57 - 80 Nm SW 27.0		3/8" - 18 NPTF 33 - 66 Nm SW 27.0		---		
Plug 18 (crankcase heater)	---	---	---			---	1/2"-14 NPTF 45 - 57 Nm SW 17.5		
Oil sight glass	1 1/8"-12 UNF 4.5 - 6 Nm ---		1 1/8"-12 UNF 4.5 - 6 Nm SW 11		1/4"-20 UNC 4.5 - 6 Nm SW 11				
Blind flange for oil screen	---	---	5/16"-18 UNC 26 - 32 Nm SW 12.7		---	---	---		
Blind flange for oil sight glass	---	---	---	1/4"-20 UNC 13-17 Nm SW 11.1		---	---	---	
Oil pump	---	5/16"-18 UNC 31 - 37 Nm SW 6.4	5/16"-18 UNC 31 - 37 Nm SW 6.4		SW 12.6	5/16"-18 UNC 31 - 37 Nm SW 12.7			
Oil pressure switch - OPS2	---	60 - 75 Nm	60 - 75 Nm				60 - 75 Nm		

<sup>1)</sup> Rotalock adapter with the exception of LH compressors

The ranges of torque values given in this specification are assembly torque. Torque after joint relaxation must be within 15% of the minimum assembly torque unless re-torque is called for and must not be above 10% of the maximum assembly torque.

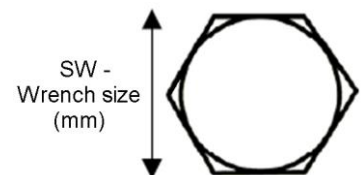

	DK K	DL, DLH L, LH	D2S	D2D 2D	D3S, D3D 3D	D4S, D4D	D6S, D6D D6T, 6T	D8S, D8D 8D
Magnetic plug <sup>2)</sup>	1/8" - 27 NPTF 19 - 30 Nm SW 12.7		1/8" - 27 NPTF 26 - 32 Nm SW 12.7		1"-16 UNC 87 - 149 Nm SW 25.4			
Cylinder head	5/16"-18 UNC 29 - 34 Nm SW 12.7	3/8"-16 UNC 57 - 68 Nm SW 14.2	3/8"-16 UNC 57-68 Nm SW 14.2		3/8"-16 UNC 57 - 68 Nm SW 14.2			
Bottom plate	5/16"-18 UNC 30 - 36 Nm SW 12.7	3/8"-16 UNC 57 - 68 Nm SW 14.2	3/8"-16 UNC 57-68 Nm SW 14.2		3/8"-16 UNC 57 - 68 Nm SW 14.2			
Mounting foot	5/16"-18 UNC 30 - 36 Nm SW 12.7	3/8"-16 UNC 57 - 68 Nm SW 14.2	3/8"-16 UNC 57-68 Nm SW 14.2		3/8"-16 UNC 57 - 68 Nm SW 14.2			
Stator cover	5/16"-18 UNC 30 - 36 Nm SW 12.7	3/8"-16 UNC 57-68 Nm SW 14.2	3/8"-16 UNC 57-68 Nm SW 14.2		1/2"-13 UNC 68-79 Nm SW 18			
Housing cover	5/16"-18 UNC 29 - 30 Nm SW 12.7	3/8"-16 UNC 57 - 68 Nm SW 14.2	3/8"-16 UNC 57 - 68 Nm SW 14.2		3/8"-16 UNC 57 - 68 Nm SW 14.2			
Mounting plate for terminals	---	---	---	5/16"-18 UNC 32 - 40 Nm SW 12.7		3/8"-16 UNC 57 - 68 Nm SW 14.2		
Terminal stud	1/4"-20 UNC 5-6.5 Nm SW 10		1/4"-28 UNF 5-6.5 Nm SW 10		1/4"-28 UNF 5-6.5 Nm SW 10			
Terminal stud thermistors	10 - 32 UNF 3.4 - 4 Nm SW 9		10 - 32 UNF 3.4 - 4 Nm SW 9		10 - 32 UNF 3.4 - 4 Nm SW 9			
Bolt for the connecting rod <sup>3)</sup>	---	---	1/4"-28 UNF 15 - 18 Nm "Torx"-screw		1/4"-28 UNF 15 - 18 Nm "Torx"-screw			

<sup>2)</sup> On LH compressors: 3/8" - 18 NPTF / 22-25 Nm / SW 12.7.

<sup>3)</sup> In case of replacement of the piston con-rod assemblies, clean the Torx screws and apply Loctite 2701.

The ranges of torque values given in this specification are assembly torque. Torque after joint relaxation must be within 15% of the minimum assembly torque unless re-torque is called for and must not be above 10% of the maximum assembly torque.

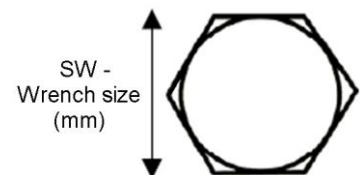

## Disclaimer

1. The contents of this publication are presented for informational purposes only and are not to be construed as warranties or guarantees, express or implied, regarding the products or services described herein or their use or applicability.
2. Emerson Climate Technologies GmbH and/or its affiliates (collectively "Emerson"), as applicable, reserve the right to modify the design or specifications of such products at any time without notice.
3. Emerson does not assume responsibility for the selection, use or maintenance of any product. Responsibility for proper selection, use and maintenance of any Emerson product remains solely with the purchaser or end user.
4. Emerson does not assume responsibility for possible typographic errors contained in this publication.



#### BENELUX

Josephinastraat 19  
NL-6462 EL Kerkrade  
Tel. +31 77 324 02 34  
Fax +31 77 324 02 35  
benelux.sales@emerson.com

#### GERMANY, AUSTRIA & SWITZERLAND

Senefelder Str. 3  
DE-63477 Maintal  
Tel. +49 6109 605 90  
Fax +49 6109 60 59 40  
ECTGermany.sales@emerson.com

#### FRANCE, GREECE & MAGHREB

8, Allée du Moulin Berger  
FR-69134 Ecully Cédex  
Tel. +33 4 78 66 85 70  
Fax +33 4 78 66 85 71  
mediterranean.sales@emerson.com

#### ITALY

Via Ramazzotti, 26  
IT-21047 Saronno (VA)  
Tel. +39 02 96 17 81  
Fax +39 02 96 17 88 88  
italy.sales@emerson.com

#### SPAIN & PORTUGAL

C/ Pujades, 51-55 Box 53  
ES-08005 Barcelona  
Tel. +34 93 412 37 52  
Fax +34 93 412 42 15  
iberica.sales@emerson.com

#### UK & IRELAND

Unit 17, Theale Lakes Business Park  
Reading, Berkshire RG7 4GB  
Tel: +44 1189 83 80 00  
Fax: +44 1189 83 80 01  
uk.sales@emerson.com

#### SWEDEN, DENMARK, NORWAY & FINLAND

Norra Koxåsvägen 7  
SW-443 38 Lerum  
Tel. +46 725 386486  
nordic.sales@emerson.com

#### EASTERN EUROPE & TURKEY

Pascalstr. 65  
DE-52076 Aachen  
Tel. +49 2408 929 0  
Fax +49 2408 929 525  
easterneurope.sales@emerson.com

#### POLAND

Szturmowa 2  
PL-02678 Warsaw  
Tel. +48 22 458 92 05  
Fax +48 22 458 92 55  
poland.sales@emerson.com

#### RUSSIA & CIS

Emerson LLC  
Dubininskaya str. 53, build. 5, 4th floor  
115054 Moscow, Russia  
Phone: +7 (495) 995 95 59  
Fax: +7 (495) 424 88 50

#### BALKAN

Selska cesta 93  
HR-10 000 Zagreb  
Tel. +385 1 560 38 75  
Fax +385 1 560 38 79  
balkan.sales@emerson.com

#### ROMANIA

Tel. +40 374 13 23 50  
Fax +40 374 13 28 11  
Ancuta.Ionescu@Emerson.com

#### ASIA PACIFIC

Suite 2503-8, 25/F, Exchange Tower  
33 Wang Chiu Road, Kowloon Bay  
Kowloon, Hong Kong  
Tel. +852 2866 3108  
Fax +852 2520 6227

#### MIDDLE EAST & AFRICA

PO Box 26382  
Jebel Ali Free Zone - South, Dubai - UAE  
Tel. +971 4 811 81 00  
Fax +971 4 886 54 65  
mea.sales@emerson.com

For more details, see [www.emersonclimate.eu](http://www.emersonclimate.eu)

Connect with us: [facebook.com/EmersonClimateEurope](https://facebook.com/EmersonClimateEurope)



Emerson Climate Technologies - European Headquarters - Pascalstrasse 65 - 52076 Aachen, Germany  
Tel. +49 (0) 2408 929 0 - Fax: +49 (0) 2408 929 570 - Internet: [www.emersonclimate.eu](http://www.emersonclimate.eu)

The Emerson Climate Technologies logo is a trademark and service mark of Emerson Electric Co. Emerson Climate Technologies Inc. is a subsidiary of Emerson Electric Co. Copeland is a registered trademark and Copeland Scroll is a trademark of Emerson Climate Technologies Inc. All other trademarks are property of their respective owners. Emerson Climate Technologies GmbH shall not be liable for errors in the stated capacities, dimensions, etc., as well as typographic errors. Products, specifications, designs and technical data contained in this document are subject to modification by us without prior notice. Illustrations are not binding.  
© 2015 Emerson Climate Technologies, Inc.

